

**GIANDEL**<sup>®</sup>

**DC to AC**  
**PURE SINE WAVE**  
POWER INVERTER

**USER MANUAL**

Model: PS-3000SAR

**Codes Table:**

F1	°F	F2	°C
F3	Battery type selection H1: ACID H2: NCM H3: LFP		
F4	Low voltage protection value setting		
F5	Countdown to turn off setting		
F15	Restore default settings		

**GIANDEL**<sup>®</sup>

[www.giandel.com](http://www.giandel.com) 769-486-2790  
[support@giandel.com.au](mailto:support@giandel.com.au)

V0.24.04

**Warning:** This manual contains important safety and operating instruction. Please read it carefully before use the unit.

**SAVE THIS INSTRUCTION MANUAL FOR FUTURE REFERENCE**

USER MANUAL

## 1. SPECIFICATIONS

ITEM	DATA
Input voltage	12VDC
Continuous power	3000W
Surge power	6100W for 2 seconds
DC input range	9.5~16VDC
Input over-voltage protection	16VDC±0.3VDC
Input low-voltage protection	Default 9.5VDC ± 0.3VDC, adjustable
Input low-voltage alarm	Default 9.8VDC ± 0.3VDC, based on set low protection voltage±0.3VDC
Output voltage	120VAC±10%
Output frequency	60Hz±1Hz
Output wave form	Pure sine wave (THD≤3%)
Efficiency	About 90%
High temperature protection	65±5°C (149±8° F)
Overload protection	3200-6000W, protected after 2 seconds
Short-circuit protection	Yes, restart in 30 seconds
Display	LCD
Function settings	1. Input battery type settings 2. Input battery low voltage protection value setting 3. Working time setting 4. Restore default settings
USB output	Fast charge USB Type-A×1, USB Type-C×1
No load current	MAX 2A (24watt)
Intelligent cooling fan	Cooling fan only works when temperature around 38±5°C or load power around 1500W, Remarks: Overload power will start the fan and stop after 60 seconds.
Working temperature	-30 ~ 60°C
Storage temperature	-30 ~ 60°C
Size (L×W×H)	44.5×18.9×10cm
Weight	5.5kg

**Remark:** Due to the continuous improvement of products, the technical parameters in this manual are subject to change without prior notice.

## 2. INTRODUCTION

The giandel power inverter product line is used for back-up power. The power inverter transforms DC (direct current) electricity into AC (alternating current) power that can be used for running a wide variety of tools and appliances. This inverter is perfect for providing mobile power in cars, boats and work trucks. The inverter can also be utilized as a back-up source of electricity in the event of an electrical failure or for several off-grid applications such as camping or in your RV.

Please read this instruction manual carefully and make sure your inverter is installed properly before using.

## 3. WARNING AND SAFETY



- **For first-time use or reuse after a long-term storage , please keep the inverter working without load for 30 minutes to 1 hour to pre-charge the capacitors, which will help extend the product's lifespan.**
- While opening the product package, please check the integrity
- While opening the product package, please check the integrity of the product and accessories. If there is any problem, please do not use it.
- While connecting and using for the first time, if there is smoke or explosion sound in the product, please stop using immediately and disconnect the product from the battery and electrical appliances. This may be caused by damage during the transportation or due to moisture during storage in the warehouse before delivery. Please contact your seller in time.
- During daily use, if there is smoke or explosion sound in the product, please don't worry, this is due to the internal fuse protection of the product. Please do not disassemble it by yourself. Please stop using the product immediately. Disconnect the product from the battery and electrical appliances. Contact the seller in time and only with seller's agreement a hired professional personnel can disassemble the product. Otherwise, it may cause electric shock, fire and serious personal injury.
- Prevent body contact with grounded surfaces such as pipes, radiators, ranges, and refrigerator enclosures during installation.
- Do not operate the inverter if under the influence of alcohol or medicine. Read warning labels on prescriptions to determine if your judgement or reflexes are impaired while taking medicine. If there is any doubt, do not operate the inverter.

- People with pacemakers should consult their physician(s) before using this product. Electromagnetic fields in close proximity to a pacemaker could cause interference to or failure of the pacemaker.

- This product cannot be used for medical and life support equipment.

- **Do not** expose the unit under direct sunlight or get close to heat sources.  
**Do not** use the unit in rain or damp environments. The normal working temperature is -30-60°C, and the ideal temperature is -30-60°C.

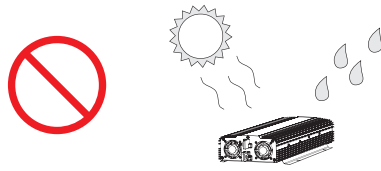

- **Avoid** the working unit contact with poor heat resistance or flammable materials.

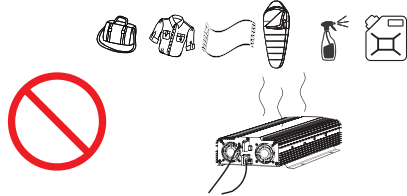

- **Keep children away from the inverter and its components**

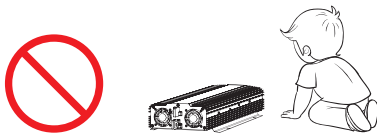

- While using inverters in vehicle, it is prohibited to use the chassis or frame as wires to connect the input terminals of inverter, the provided cables or special cables should be used.



- This inverter is suitable for electronic systems with negative grounding, and should not be connected to electronic systems with positive grounding (currently, most vehicles and ships use negative grounding)

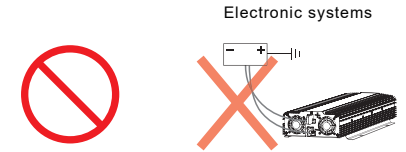

- **Do not** disassemble the unit randomly: it may cause fire or electric shock. This device should only be serviced by a qualified technician. This item does not have any serviceable parts.

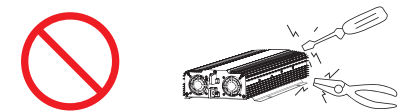

- When the inverter is installed in vehicle, it must be turned off before entering the petrol station to ensure safety.



- Keep the output port clean and tidy

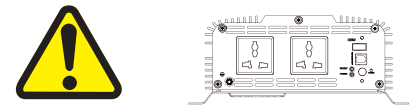

- Disconnect the inverter and battery if not use for a long time to avoid accidental start-up.

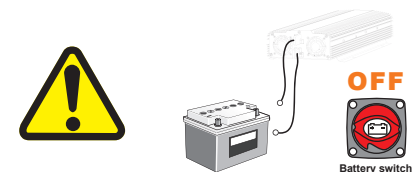

- Tighten connection needed, poor connection will cause voltage drop or posts melt. Reversely connect the cables will blow the fuses. Do not reverse connect cables.

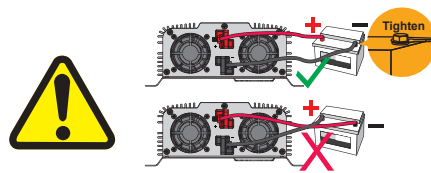

- The lithium battery usually has its own protection voltage which may be different with inverter's. The battery usually shuts down for over charging at about 14.5V which will cause inverter stop working for no input voltage or HI for direct charging from charger.

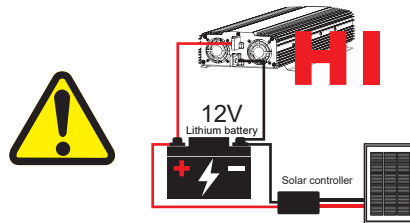

#### 4. PARTS LIST

##### (1. DC Input Side)

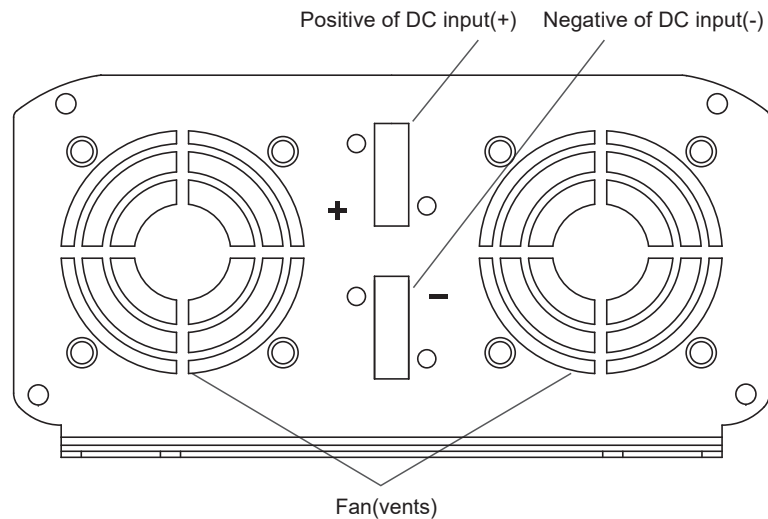

##### (2. AC Output side)

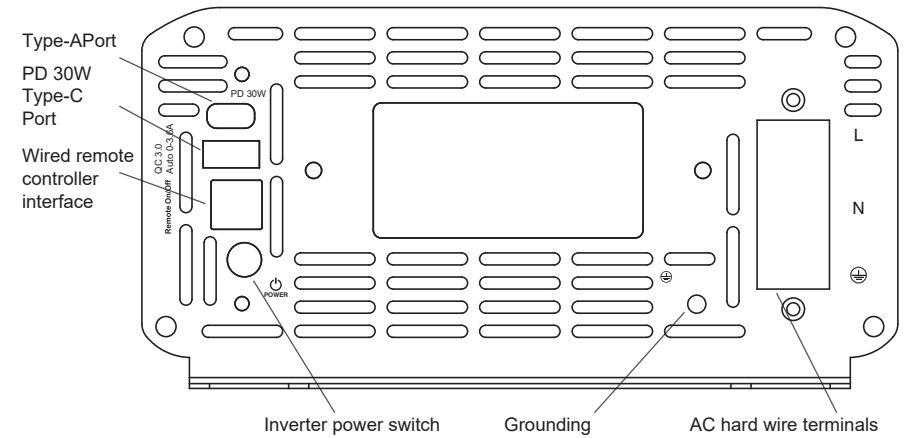

##### (3. Remote controller box)

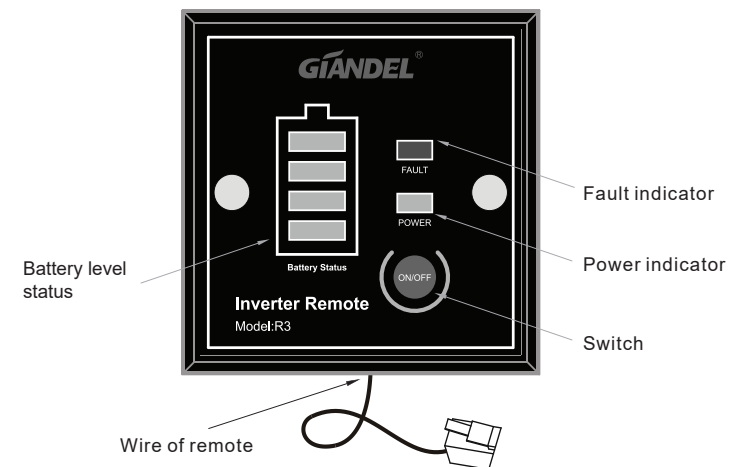

## 5. INSTALLATION

### 1. Installation guide

Firstly, sufficient space should be ensured to install the inverter and the installation position must meet the following requirements:

- (1) Dry: Do not drip water or other liquids onto the inverter
- (2) Cool: The working environment temperature of the product is  $-30-60^{\circ}\text{C}$ , preferably a temperature of  $-30-60^{\circ}\text{C}$ , at a temperature as low as possible within this range
- (3) Ventilation: There should be a certain distance between inverter and other objects, to avoid blocking the products vents.
- (4) Clean: Do not install the products in the dusty, wood chips or other particles, If cooling fan is turned on, the particles involved in the inside of the product, thus affecting the normal work.
- (5) While inverters and batteries connected, will produce arcs or sparks, do not use it around flammable objects such as gasoline, alcohol, etc for risk of fire or explosion.
- (6) It is recommended that the product be unloaded for half an hour before use, and products stored for more than 3 months should also be unloaded for half an hour before being loaded. This is to better protect the product's service life.

### 2. Install the inverter

Mounting position precaution

1. The inverter should be installed indoors or in a carriage on a platform or support frame with good load-bearing capacity, and should not be installed in a narrow space. A space of 8" (20cm) should be reserved around it for heat dissipation, ventilation, and to avoid collisions between the inverter and the inner wall. It should be kept away from rainwater, dust, and kept clean, dry, and tidy.
2. Be sure to affix the product with screws to keep it from falling or moving

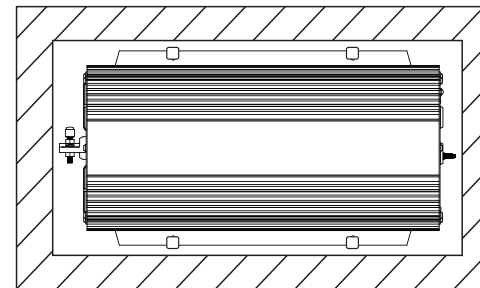
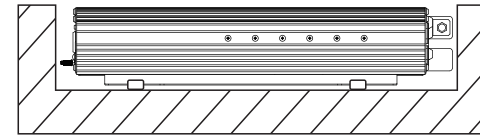
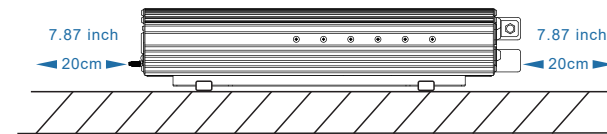

Mounting Directions: The inverter can be mounted to a suitable horizontal or vertical panel. Please keep 8" (20cm) adequate ventilation space for the cooling fan. If you mount the inverter vertically, please keep the DC terminals side downward.

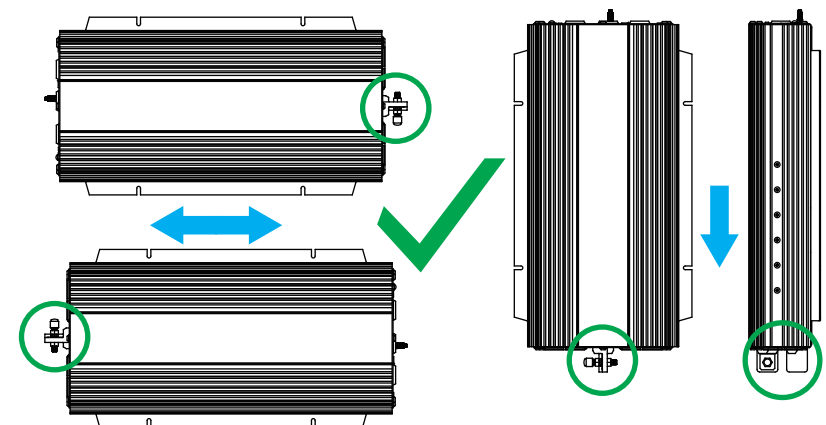

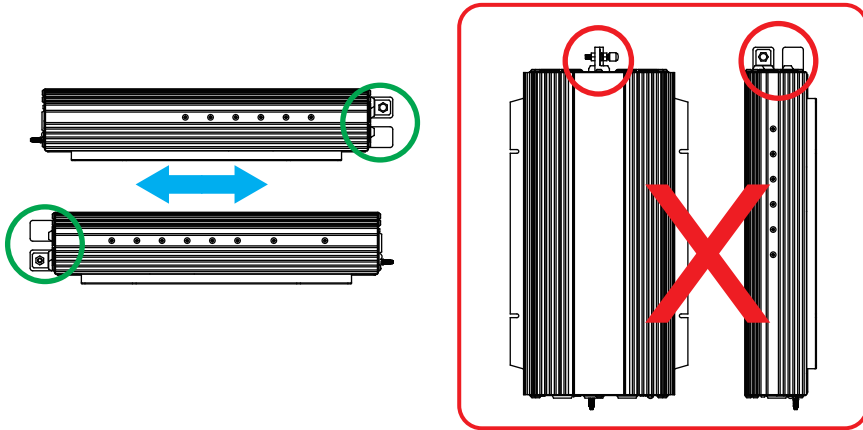

### Installation in a truck or trailer :

- (1) Do not install the unit outside the carriage or at the bottom of the frame. Shock proof pads must be installed for firmly fixing .
- (2) If possible, the cable length should be shortened to within 2 meter and refer to the cable length specification table in the manual to choose suitable cables.

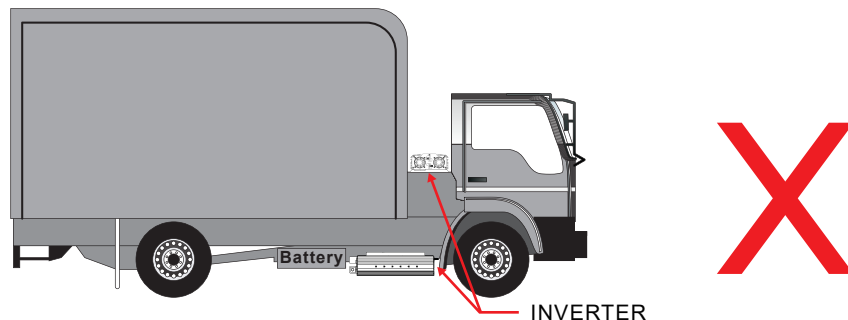
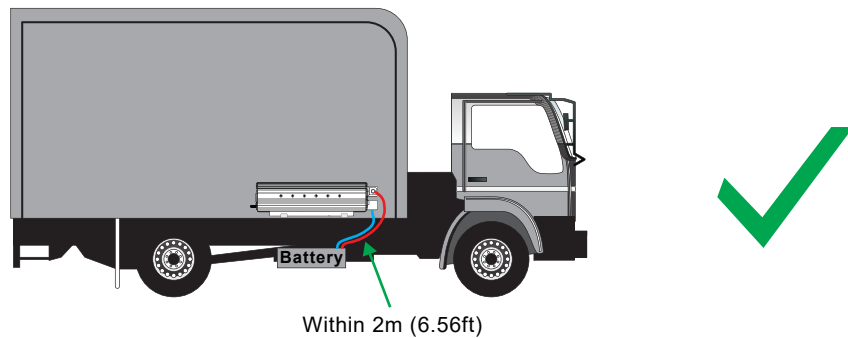

### 3) Installation of remote control box

- (1) Fixed on the plane with an opening, then fix two screws directly on the position of two installation holes of the remote control box.
- (2) The remote control box can also be installed on the base of 86X86mm electrical socket.
- (3) Connect the connection between the remote control box and the inverter.

**Note:** This product can also be used as a common inverter without connecting the remote control box.

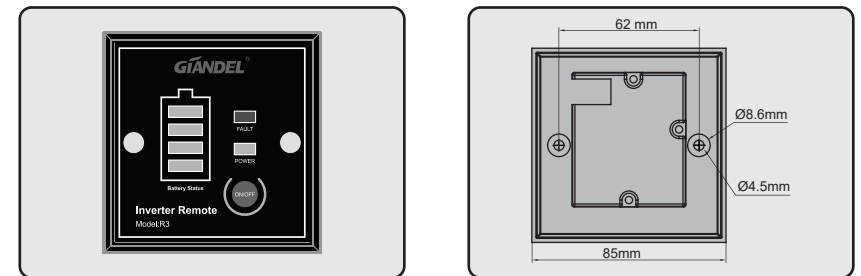

## 6. BATTERY

### 1. Current and voltage

The battery is used to supply the DC input voltage required by the product, and its rated voltage must be in line with the rated input voltage of the inverter, beyond the input voltage range of the inverter, and the cross connection will cause the product to be under voltage or under voltage protection.

At the same time, the battery must provide sufficient current for inverter, a small capacity battery is not able to drive high power appliances, in this case, usually due to excessive current and battery discharge the battery terminal voltage low, undervoltage protection products appear.

The simple formula for the battery current is the load power / the battery voltage. As the inverter itself will be part of the loss, so the actual current will be greater than this value of about 10%. For example: the battery voltage is 12VDC, the load power is 400W, then the actual current size of the battery is about  $400W \div 12V \times 110\% = 37A$ .

## 2. Battery working time

The using time of battery depends on battery capacity (AH) and the power of the connected load (W), the calculating method is: Time (hours) = battery capacity (AH) × battery output voltage (V) × efficiency rate ÷ electrical power of using (W) such as the 12V DC input inverter uses the 12V battery, if the battery capacity is 200AH and at this time the inverter is driving 400W power load, the efficiency rate is 90% when the battery is full, according to the formula above, the battery use time =  $200(AH) \div (400 \div 12 \times 110\%) = 5.4$  (Hour). This means the battery can be used for 5.4 hours.

**NOTICE:** The nominal battery capacity is the discharge capacity in 20 hours discharge rate, under the condition when the discharge current exceeds this value, the discharge capacity will be reduced, the corresponding discharge time will be shortened than the calculation value, this part of the specification can refer to battery manufacturer, and whether the battery fully charged will also affect the results.

## 3. Battery size recommendation

Inverter Version	Inverter Rating power	Max Current (A)	Battery for lasting 1 hour	Battery for lasting 2 hours	Batteries for N hours
12V	600W	57	70	140	Nx70AH
	1000W	95	115	230	Nx115AH
	1200W	114	140	280	Nx140AH
	1500W/1600W	152	180	360	Nx180AH
	2000W/2200W	209	250	500	Nx250AH
	2500W	238	290	580	Nx290AH
	3000W	285	340	680	Nx340AH
	4000W	380	460	920	Nx460AH
	5000W	475	570	1140	Nx570AH

### NOTE:

- The battery specifications provided in the above table are for reference only. The selection and use of the battery should also refer to the battery instructions, especially for Lithium battery and LifePO4 batteries, such as: whether the maximum discharge current of the battery meets the working current of the product; Whether the low-voltage protection of the battery is within the working range of the product, etc. Furthermore, whether the battery is fully charged or false capacity labeled which will lead to insufficient working hours of the product. According to the life span of the battery, the battery capacity will decline after long term of use, which will also affect the working hours of the product.
- Recommends using "Deep Cycle" or Marine rated batteries.

## WARNING:

- Do not connect different brand or different capacity, specification of batteries in series or parallel, it is unsafe and may damage the batteries or inverter.
- Inverters are not recommended to be used when the battery is being charged; When the inverter is used while charging battery, the voltage fluctuation at both ends of the battery is relatively large, and the ripple voltage and current will cause the following adverse factors:
  - The battery cannot be fully charged when the inverter is working, and the charging voltage ripple will affect battery life.
  - While charging battery, the ripple voltage and current are large, and the input voltage and current are unstable, which will affect the working efficiency of the inverter and easily damage the product.
  - The charging device that charges the battery may cause high charging voltage, which will trigger the inverter input High Voltage protection fault and affect the work of the product. If it happens, the charging device must be disconnected.

## 7. CONNECTION

### 1) Grounding

The power inverter has a terminal on the back panel marked "Grounding" or "⊕". This is used to connect the chassis of the power inverter to the ground.

The ground terminal has already connected to the ground wire of AC output receptacle through the internal connecting wire. The ground terminal must be connected to the ground wire, which will vary depending on where the power inverter is installed.

1. In some fixed available position	Connect the ground terminal to the earth
2. Indoor conditions	A. Connect to household metal water pipes, metal frames (door frames, window frames) connected to the earth B. Connect to the nails on the wall or ground which contact to the earth C. Connect to the grounding system of the mains grid which is connected to the ground wire of the socket (Note: this connection must be operated by a professional electrician)
3. Outdoor conditions	Connect one end of earth wire to the inverter grounding terminal, the other end to the nail and insert to the earth.
4. In a Vehicle, boat or ship	Connect to the chassis of vehicle or grounding system of boat, ship.

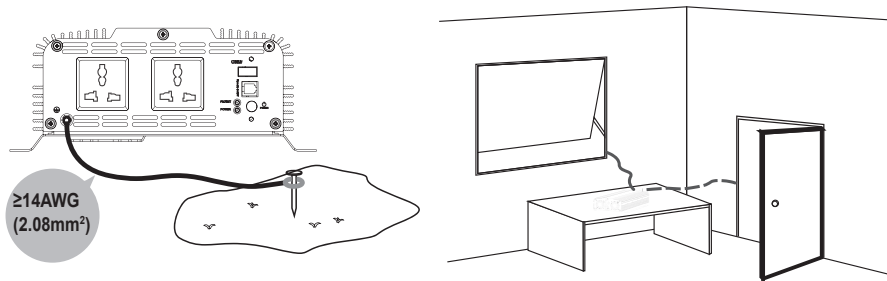

**WARNING:** ⚠

- Connect the earth terminal of inverter to any wall, floor or objects connected to the ground.
- To make sure the firmness of the connection. The ground wire must be 14AWG (2.08mm<sup>2</sup>) or even larger.
- Do not operate the power inverter without connecting to ground. Electric shock hazard may result.

**2) Connect to battery**

- (1) Please do all the safety precautions before connection, and then check whether the battery voltage is in accordance with the input voltage of the inverter. Only the 12 voltage of the battery accords with the requirements can be allowed to connect with the 12V inverter.
- (2) Secure the provided Negative (black) DC cable connect to the Negative (-) bolt on the inverter, and the other end to the Negative (-) post on the battery.

- (3) Secure the provided Positive (Red) DC cable to the Positive (+) bolt on the inverter, and the other end to the Positive (+) post on the battery.
- (4) The nuts of the connection posts must be tightened to ensure well connected.
- (5) The input cables must be able to withstand sufficient current. If its cross-sectional area is too small, it will cause a significant voltage drop, which will prevent the product from carrying high-power loads. Refer to the below table to choose suitable cables.

Inverter input voltage	Rating power	Max current of cable	Specification of wire length≤1m (Cross section area)	Specification of wire length (1m-2m) (Cross section area)	Specification of wire length≤N m (Cross section area)
12V	1000W	100A	6AWG(13.30mm <sup>2</sup> )	3AWG(26.67mm <sup>2</sup> )	N×6AWG(N×13.3mm <sup>2</sup> )
	1500W	150A	4AWG(21.15mm <sup>2</sup> )	1AWG(42.41mm <sup>2</sup> )	N×4AWG(N×21.15mm <sup>2</sup> )
	2000W	200A	3AWG(26.67mm <sup>2</sup> )	0AWG(53.49mm <sup>2</sup> )	N×3AWG(N×26.67mm <sup>2</sup> )
	2500W	250A	2AWG(33.62mm <sup>2</sup> )	00AWG(67.43mm <sup>2</sup> )	N×2AWG(N×33.62mm <sup>2</sup> )
	3000W	300A	1AWG(42.41mm <sup>2</sup> )	2×1AWG(84.82mm <sup>2</sup> )	N×1AWG(N×42.41mm <sup>2</sup> )

**NOTICE:**

1. The above table is only for your reference. In practice, the thick wire can be replaced by two thin parallel wires if only the total section acreage of the wire meets the requirements.
2. In high current, the input DC wire may produce voltage drop, therefore, the operating voltage should be subject to the value on the terminals. If the voltage drop is too large, you can increase the acreage of the section or reduce the length of the lead. The recommended length of lead is less than 1m.
3. Connect cathode wire of the battery to the cathode terminal (black) on the back panel of inverter and then connect the anode wire of the battery to the anode terminal (red) on the inverter, and fix them.

**WARNING:** ⚠

- (1) Please wear eye patch and work clothes when working around the battery to avoid the acid and corrosive objects harm your eyes and skin.
- (2) Prepare enough water and soap. In case the acid materials contact eyes or skin, clean it by soap and water as soon as possible. If the acid materials spay to your eyes accidentally, clean it by cold water immediately and then sent to hospital.



- (3) Do not put any combustible material in the location of installation for spark will result when it is connected to the battery.
- (4) Keep good ventilation. The battery may produce a little inflammable gas when it works, so keep away from the inverter and it is better to install them in different space.
- (5) Fix the connecting wire of the input DC, or it will result the over-reduction of the voltage or over-temperature of the wire.
- (6) Reverse connection of the polarities or the short circuit will burn the fuse or result the permanence damage of the internal components.
- (7) Take away the metal accouterment, such as ring or watch, while installing to avoid the short circuit.
- (8) Although there is over-voltage protection, it may also cause damage of the inverter if the input voltage is too high.

### 3) Connection of the AC appliance

Insert the power plug of the AC appliance load into the output AC receptacle of the inverter directly.

#### **WARNING:**

1. Check the power cord of appliances. If it is damaged, it should be replaced.
2. Inductive loads like refrigerator, A/C, pump, Microwave etc require a large rush of power to start, they can draw up to 3-10 times of their rating power, so with same rating power, the inverter may not power up the inductive loads. An inverter with 3-10 times of the rating may be required.

Resistive Loads like toasters, heat pads, electric stove etc work by generating heat which draw high current, a typical battery bank would be drained quickly. Therefore bigger battery group may require.

#### **Caution:** Don't overload the inverter.

### 4) Hard wire block terminals

The hard wire block terminals are specially designed for heavy duty loads over 1500Watts. Please refer to the bellow table to choose suitable wires.

Inverter input voltage	Max power of load	Output Voltage	Max current	Wire for 1 meter	Wire for 2 meter	Wire for N meter
12V	2000W	120V	17A	13AWG 2.6mm <sup>2</sup>	10AWG 5.26mm <sup>2</sup>	N×2.6mm <sup>2</sup>
	2200W		18A	13AWG 2.6mm <sup>2</sup>	10AWG 5.26mm <sup>2</sup>	N×2.6mm <sup>2</sup>
	2500W		21A	12AWG 3.3mm <sup>2</sup>	9AWG 6.63mm <sup>2</sup>	N×3.3mm <sup>2</sup>
	3000W		25A	11AWG 4.2mm <sup>2</sup>	8AWG 8.37mm <sup>2</sup>	N×4.2mm <sup>2</sup>
	4000W		33A	10AWG 5.26mm <sup>2</sup>	7AWG 10.55mm <sup>2</sup>	N×5.26mm <sup>2</sup>
	5000W		42A	9AWG 6.63mm <sup>2</sup>	6AWG 13.30mm <sup>2</sup>	N×6.63mm <sup>2</sup>

## 8. USAGE OF INVERTER

### 1. Preparation before use:

- 1) Check the output voltage and capacity of the battery, which should meet the requirements for inverter use.
- 2) Connect the battery cables of the inverters to the battery, ensure that the polarity is not reversed, and ensure good contact.
- 3) For first-time use or reuse after a long-term storage, please keep the inverter working without load for 30 minutes to 1 hour to pre-charge the capacitors, which will help extend the product's lifespan.

### 2. On/Off Operation

- 1) Turn on inverter: Long press the ON/OFF button on the inverter or remote control box until you hear a beep before releasing it (more than 1 second), and at the same time, the LCD screen will light up. The cooling fan will rotate for 2 seconds to stop, and finally the buzzer will beep again to complete the startup.
- 2) Turn off inverter: Long press the ON/OFF button to hear a beep to complete the shutdown.
- 3) Two beeps indicate successful startup of the inverter

### 3. USB Output

- 1) USB Type-A port × 1:
  - QC output: 5V--3.6A, 9V--2.5A, 12V--2A Note: (Test voltage is above 13V)

- Fast charging with a maximum output of 24W
  - Supports fast charging protocols: QC3.0/QC2.0/BC1.2DCP/AFC/SCP/CP/PE2.0
- 2) USB Type-C port × 1:
- PD output: 5V–3A 9V–3A 12V-3A Note: (Test voltage is above 13V)
  - Maximum output power of fast charging 36W
  - Support for fast charging: PD3.0/ PD2.0/ PPS/ BC1.2DCP/ QC4/ QC3.0/ QC2.0/AFC/FCPS/SCP/PE2.0
  - The fast charging output protocol is determined by the mobile phone charging request, and the maximum power that can be achieved during charging is subject to actual testing.

#### 4. Working temperature display (F1/F2):

1. Fahrenheit temperature: Click the ON/OFF button to display F1 and switch to Fahrenheit temperature display. Click the ON/OFF button again to return to AC voltage display.
2. Celsius temperature: Double click the ON/OFF button to display F2 and switch to Celsius temperature display. Click the ON/OFF button again to return to AC voltage display.
3. The displayed temperature is the working temperature of the shell near the front MOSFET (thermistor position), with a tolerance of  $\pm 5\text{ }^{\circ}\text{C}$ .

#### 5. Input battery type settings (F3):

- 1) The battery type switching function is represented by F3, and "H1" lead-acid battery is initially selected by default.
- 2) Enter battery type selection settings: Click the ON/OFF button continuously until F3 is displayed on the screen. Release the button to enter the settings.
- 3) Battery type selection operation: Click the ON/OFF button to cycle through the selection of battery type, and the low-voltage protection voltage value will be displayed. The battery type option and abbreviation of the name represent:

"H1" ACID indicates lead-acid battery, and its low voltage protection value is 9.5V

"H2" NCM indicates Ternary lithium battery (4 series) and its low voltage protection value is 11.2V.

"H3" LFP (LiFePO4) indicates lithium iron phosphate battery (4 series), and its low voltage protection value is 10.4V.

Automatically save settings and exit after 5 seconds of inactivity.

#### 6. Input battery low voltage protection value setting (F4):

- 1) The low voltage protection value setting function of the battery is represented by F4, and the initial protection value defaults to 9.5V.
- 2) Enter the low voltage protection settings for the input battery: Click the ON/OFF button continuously until F4 is displayed on the screen. Release the button to enter the settings.
- 3) After entering the settings, it will enter the parameter adjustment state and flash to display the current low voltage protection value being adjusted. By clicking on ON/OFF button, it can be cyclically adjusted between 9.5-11.5V. After 5 seconds of no action, it will stop flashing and exit the adjustment state.

#### 7. Working time setting (F5)

- 1) The working time setting is represented by F5, which can be set for 1 second to 100 hours, and can be set for hours and minutes with an error of  $\pm 2$  seconds per hour.
- 2) Enter the working time setting interface: Click ON/OFF button continuously until F5 is displayed on the screen, then release the button to enter the settings.
- 3) In the last 10 seconds of the countdown, there will be a beep sound prompt indicating the inverter protection status, and the timing will not be affected. If it is turned off midway, the timing setting will become invalid.
- 4) After the timer ends, the inverter stops working and the display screen turns off. Long press the ON/OFF button to restart.
- 5) Working time adjustment operation:

- ① When flashing, it is in an adjustable state, switching from hour and minute, and switching every 5 seconds.
- ② Short press of the button can increase the value, long press of the button can reset the value. If the shutdown time is not set, it will automatically exit the setting after 10 seconds.

#### 6) Working time setting interface:

- ① After setting the working time, it will automatically return to the main interface and display the working time in hours, minutes, and seconds.
- ② Click the ON/OFF button on the display working time interface to return to the main interface and run the countdown shutdown timer in the background. Long press the button until it beeps to clear and close the countdown shutdown task.
- ③ If there is a countdown shutdown task, continuously click the ON/OFF button on the main interface until F5 is displayed, and the shutdown countdown time will be displayed again.

#### 8. Automatic shutdown function of buzzer protection alarm:

After protection, it will beep for 1 minute and stop beeping.

#### 9. LCD screen backlight automatic turn off function:

The screen backlight will automatically turn off after 1 minute, and clicking the ON/OFF button once can turn on the screen backlight again for 1 minute.

#### 10. Restore default settings (F15):

- 1) The function of restoring default settings is represented by F15.
- 2) Enter settings: Click the ON/OFF button continuously until F15 is displayed on the screen. Release the button to enter settings.
- 3) Restore default settings operation: After entering the settings, F15 and RES will be displayed. If you click the ON/OFF button, it will automatically restore the default initial parameters of all functions and restart. Otherwise, if there is no action, it will automatically exit the settings after 5 seconds.

#### 9. Soft start technology

This inverter has soft start technology, which means that after turning on the inverter switch, the output voltage gradually increases from low to normal value. This feature can reduce the large current surge at the moment of starting the appliance, helping to start loads those are difficult to start.

#### 10. OUTPUT VOLTAGE AND WAVE FORM

The output wave form of this inverter is Pure Sine Wave, which is much like the one from utility-supplied AC electricity, even more purer; pure sine wave is applicable in most of loads, including electrical equipments, such as Linear Adaptor, switching power supply, transformer, and motor and so on.

Comparing with Modified wave form, for inductive loads such as refrigerator and electric fans, pure sine wave form can improve its power factor and the battery's efficiency and reduce working noises effectively from appliances. For capacitive loads such as adapter of lap-top, pure sine wave can lower the rush current at work and reduce interferences to increase reliability and prolong the life of the product.

Pure Sine Wave Output  
(120 VAC Model)

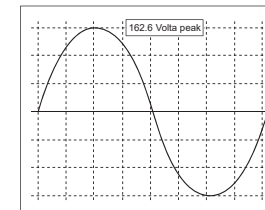

#### 11. Work instructions

##### Normal working state:

##### 1. LCD main interface display:

- |                    |                     |
|--------------------|---------------------|
| ① DC input voltage | ② AC output voltage |
| ③ output frequency | ④ output power      |

- ⑤ Battery
- ⑥ OUTPUT-AC working icon
- ⑦ pure sine wave symbol
- ⑧ 4-bar output power icon indication (subject to the actual displayed power on the LCD) ,
  - Does not show load icon < 750W
  - Light up the first bar icon  $\geq 750W$
  - Light up the second bar icon  $\geq 1500W$
  - Light up the third bar icon  $\geq 2250W$
  - Light up the fourth bar icon  $\geq 3000W$
- ⑨ 4-bar battery levels indicator (subject to the actual displayed voltage on the LCD)
  - The first bar flickers  $\leq$  the setting protection voltage (default  $9.5V$ ) +  $0.3V$
  - Light up the first bar icon > the setting protection voltage (default  $9.5V$ ) +  $0.3V$
  - Light up the second bar icon  $\geq 11.5V$
  - Light up the third bar icon  $\geq 12.5V$
  - Light up the fourth bar icon  $\geq 13.5V$

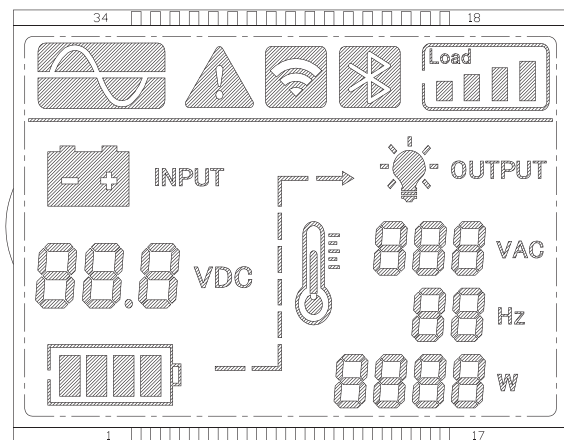

2. While the inverter working, LCD screen will display input voltage, output voltage, pure sine wave symbol, frequency, bars of load. When the inverter enters the protection state, the LCD will display a warning symbol and the current protection state.

## 12. Protection functions

1. Input Low Voltage alarm: Set the voltage value based on the battery type selected by the (F3/F4) setting function +0.3V, Intermittent beep for 1 second/time, and the first battery icon on the LCD screen flashes. The backlight on the screen will remain on during the alarm status.
2. Input low voltage protection (LO) and restore voltage: Set the voltage value according to the battery type selected by the (F3/F4) setting function, buzzer alarm & LCD display code "LO" & triangle warning icon. When the input voltage returns to 12.5Vdc, the inverter returns to normal operation.
3. Input over voltage protection (HI) and recovery voltage: DC16V, buzzer alarm & display code "HI" & triangle warning icon. When the input voltage returns to 14Vdc, the inverter returns to normal operation.
4. Output short circuit protection (OL): Yes, can be restarted. The buzzer will sound an alarm and restart after 30 seconds.
5. Work protection temperature (OH) (based on display):  $65^{\circ}\text{C} \pm 5^{\circ}\text{C}$ , buzzer alarm & display code "OH" & triangle warning icon, and display Fahrenheit temperature (AC voltage position) and Celsius temperature (power display position) simultaneously. Restart when the temperature is  $\leq 50^{\circ}\text{C}$ .
6. AC voltage output low abnormal warning and protection (ACL):  $\leq 95\text{Vac}$  (based on the actual LCD display), there will be intermittent buzzing & voltage data & pure sine wave icon flashing for 1 second/time. Once ac output  $\geq 100V$  returns to normal within 10 seconds, otherwise it indicates that the inverter has an abnormal AC voltage output fault, and enters protection & buzzer alarm & display code "ACL" & triangle warning icon, and do not recover after protection.
7. Output power overload reminder and protection (OL) (based on display)
  - (1) Output overload reminder power:  $3200W \leq \text{load} \leq 6100W$ , intermittent buzzing & power data and four bar power icon flash for 1 second/time, enter overload protection state after 2 seconds.

(2) Output overload reminder power recovery: load  $\leq$  3000W

(3) Output peak protection power: load  $\geq$  6100W, buzzer keeps ringing, restart after 30 seconds.

(4) Test conditions for peak power output: At full load, the input voltage is 13Vdc and the instantaneous battery current is more than 600A.

### 13. HOW TO CHANGE FUSE

1. Firstly disconnect the inverter and external batteries, solar panels, load etc all the connections.
2. Unscrew the side plate screws and pull out the bottom plate.
3. Use pliers to clamp car fuse inside the product, and pull out .
4. Replace the same specifications of the car fuse, and then install the bottom and side panels, and screw well.

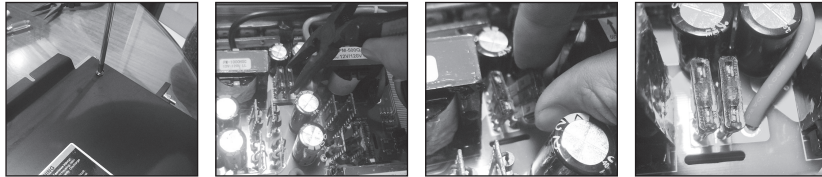

### 14. TROUBLESHOOTING TIPS

PROBLEM	REASON	SOLUTIONS
<b>No output voltage and buzzer sounds continuous or intermittent and shutdown?</b>	Input Battery voltage is below 9.8V $\pm$ 0.3V(12V version)	<ul style="list-style-type: none"> <li>● Recharge the battery</li> <li>● Battery may be too small. Please refer to instruction for recommended battery sizes.</li> <li>● Check the cable connections and ensure the cable sizes are sufficient. Use provided cables if included. The shorter and thicker cables the better.</li> <li>● One or some of the batteries in the battery group may be defective, remove the defective battery</li> <li>● The inline fuse (if has) may be too small.</li> </ul>
	High input DC voltage. The input battery voltage is above 16V(12V version)	<ul style="list-style-type: none"> <li>● Check the battery charger is not connected to the battery.</li> <li>● Do not use it when the battery is charging. Disconnect the solar panel while the battery is fully charged.</li> <li>● Confirm whether the input battery is correct.</li> </ul>
	Overload	Reduce the load power or choose a bigger inverter.
	Over temperature	<ul style="list-style-type: none"> <li>● Turn off the load and let it cool naturally for 10 to 30 minutes. Restart it after it resumes to normal temperature. Reduce the load .</li> <li>● Avoid blocking the vent and improve the ventilation condition.</li> </ul>
<b>No AC output voltage?</b>	<ol style="list-style-type: none"> <li>1. The power switch is off.</li> <li>2. Poor contact with battery.</li> <li>3. Inline fuse(if has) may be burnt.</li> </ol>	<ul style="list-style-type: none"> <li>● Press the power switch for 1-2 second to turn it on, it is a long press type switch.</li> <li>● Check the cables and make sure they are tightly connected .</li> <li>● Check the inline fuse is fine or remove circuit breaker to test the inverter again.</li> <li>● One or some of the batteries in the battery group may be defective, remove the defective battery.</li> </ul>
<b>Cannot drive the load even less power than the size of inverter?</b>	<ol style="list-style-type: none"> <li>1. Power of load is too large, or the actual power of the appliance exceeds the max power of inverter.</li> <li>2. The starting power is larger than rated power (especially for appliances with motor, this kind of inductive loads require a large rush of power to start. Even a 80W fridge may need a 1000 watt inverter) .</li> <li>3. Battery is too small.</li> </ol>	<ul style="list-style-type: none"> <li>● Reduce the load power, or turn on the appliance first, then turn on the inverter.</li> <li>● Choose a bigger inverter.</li> <li>● Change a bigger battery and ensure fully charged.</li> <li>● The inline fuse(if has) may be small.</li> <li>● Choose the shorter and thicker cables.</li> </ul>

PROBLEM	REASON	SOLUTIONS
<b>Tester indicated "Open Ground"</b>	This is because it is not connected to a "true Earth ground", meaning it is not connected to a metal rod stuck in the Earth. It would be impossible to do so in a boat or car while moving. The power inverter DOES NOT and cannot create a true Earth ground on its own.	<ul style="list-style-type: none"> <li>• Don't need the tester to do the Grounding Test.</li> <li>• Refer to the manual to do the Grounding</li> <li>• Choose an inverter with GFCI sockets</li> </ul>
<b>Starting alarm ?</b>	The main reason is that the instantaneous current is too large, which leads to the detection of low voltage and triggers under-voltage alarm.	<ul style="list-style-type: none"> <li>• Please restart the inverter several times.</li> </ul>
<b>Got 40V or so while testing inverter's ground wire and zero line?</b>	This voltage has no meaning, zero line can be ground.	<ul style="list-style-type: none"> <li>• This is normal, there is no current leakage.</li> </ul>
<b>Cooling Fan noisy</b>	Object may be stuck in fan	Inspect fan area at rear of unit to ensure no object is obstructing fan movement

 **WARNING: REVERSE CONNECTED THE CABLES WILL DAMAGE THE INVERTER AND VOID YOUR WARRANTY!**

**If the unit still doesn't work normally after using all the methods above, it maybe the internal faults of the circuit. Please contact seller for warranty.**

## 15. WARRANTY

GIANDEL warrants all the brand new products against defects in materials and workmanship for 18 months effective from the date of purchase.

GIANDEL will replace any products that are found to be defective due to manufacturer flaws based on eligibility. Refunds issued by GIANDEL must be purchased directly from GIANDEL and are only available to the original purchaser within the first 30 days. We do not issue refunds for items bought by third party retailers.

The warranty is not transferable. GIANDEL is not responsible in any way for any damages, losses or inconveniences caused by equipment failure by user negligence, abuse or use non-compliant with the user manual or any additional safety, use or warnings included in the product package and manual.

The warranty only covers purchase within the 48 contiguous states of United States of America if you purchased from the USA. For purchases made outside the 48 contiguous states such as AK, HI, PR or Canada, we will replace the unit under the warranty upon receipt of a proven defect by Video or Picture. However, the replacement will only ship to a freight forwarder or address within the 48 contiguous United States. The consumer is responsible for arranging shipment outside of the 48 contiguous states.

GIANDEL assumes no liability for damage caused using this product other than for its intended use or as instructed in the user manual. Some states do not allow this exclusion or limitation of incidental or consequential losses, so the foregoing disclaimer may not apply to you. This warranty gives you specific legal rights and you may also have other rights which may vary from state to state.

### **The following situations will void warranty:**

1. The box is distorted, damaged or changed and interior parts damaged for an exterior hit or drop not reported at delivery time;
2. Connect the battery cables incorrectly and reversing the polarity
3. Dismantled or repaired the unit by an unauthorized person
4. The product was damaged for incorrect installation or operation.
5. Plug any AC power / Shore power / Generator to AC outlets.

### **Defective products & Returns**

If your product is defective within the warranty period, please email our Customer Care Team at [support@giandel.com.au](mailto:support@giandel.com.au). To expedite your issue, please provide the following 4 items:

1. Copy of the invoice, order information showing the date of purchase.
2. Serial Number which usually found nearby the side cooling fan.
3. Picture or video of the issue or defect that you are experiencing
4. Shipping address information.