

TEC103

Temperature Controller

PRODUCT INTRODUCTION MANUAL

Striving for the Bright Future of Precision Optical Measurement.

Single Channel Temperature Controller (TEC103 Series)

01 Product Functions

TEC103 is primarily used for temperature measurement and control in optical components, such as lasers, detectors, and small sample chambers.

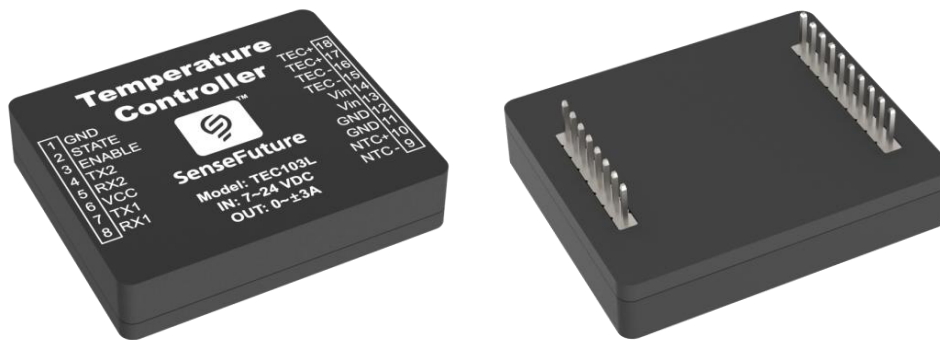

Figure1 TEC103

02 Product Features

- Thermal measurement sensitivity of 0.1 mK, long-term drift (over 24 hours) less than 1 mK.
- Temperature control stability of $\pm 0.001^{\circ}\text{C}$, suitable for most scenarios, including the stringent temperature control requirements for semiconductor lasers.
- Optional bipolar or unipolar output.
- Capable of limiting the maximum rate of temperature change.
- Supports NTC (Negative Temperature Coefficient) thermistor temperature sensors.
- Chip-level design, facilitating integration into circuit board designs.
- Features overheat protection for the circuit board, ensuring reliable performance.
- Allows direct parameter setting via the display control module, with settings retained in memory after power loss, simplifying production operations.
- Provides a comprehensive set of serial port control commands, offering an open platform for customization and integration.

03 Product Parameters

Table1 Basic Parameters of TEC103

PARAMETERS	MODEL			UNIT
	TEC103L	TEC103	TEC130 (Pending Launch)	
24-hour Temperature Measurement Stability (with the matched thermistor)	<0.001@20°C		<0.001@20°C	°C
Temperature drift caused by ambient temperature	0.0001		0.0001	°C/°C
Optimal Temperature Control Stability (related to the overall system)	±0.01	±0.001	±0.001	°C
Temperature Change Limit Setting Range	0.01~2.5		0.01~2.5	°C/s
Temperature Setting Method	UART		UART Analog Voltage: 1V =10kΩ	
Power Supply Voltage (Short-term Maximum Voltage: 28V)	7~24		7~24	V
Output Polarity	Bipolar、Unipolar		Bipolar、Unipolar	V
Number of Channels	1		1	
Maximum Output Voltage	±90%Vin (Settable)		±90%Vin (Settable)	
Output Current Range	0~±3		0~±30	A
Ambient Temperature	-55~60		-55~60	°C
Ambient Humidity	0~98		0~98	%RH
Thermal Dissipation Requirements	No Additional Thermal Dissipation Needed Within Rated Operating Range			
Circuit Board Overheat Protection	Yes			
Power Loss Memory	Yes			
PID Parameters	User Adjustable			
Size	46.5*39.0*9.6		—	mm
Weight	≈30		—	g

04 Interface Introduction

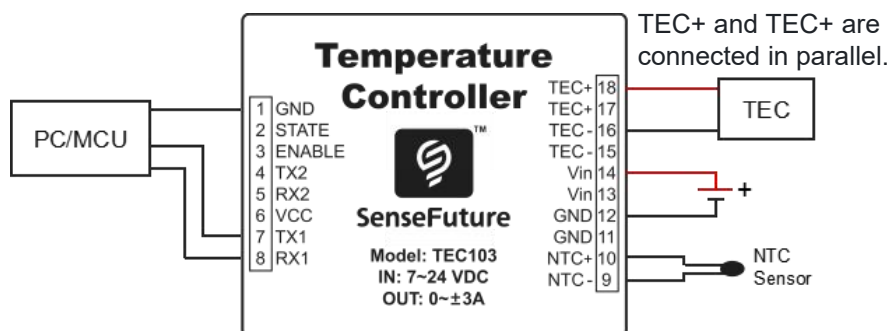

Figure2 Wiring Diagram of TEC103/TEC103L

Table2 Pin Definition Table for TEC103/TEC103L

Pin Number	Pin Name	Pin Type	Pin Definition (High Level: 3.3V, Low Level: 0V)
1	GND	Input	Power Input Negative Pole (Low Current).
2	STATE	Output	Temperature Control Status Output. High Level: Temperature control is functioning normally (temperature control error < 0.01°C). Low Level: Temperature control anomaly detected (temperature control error ≥ 0.01°C). The temperature control standard of 0.01°C can be set.
3	ENABLE	Input	Output Enable Pin. High Level (Default): Enables temperature control output. Low Level: Disables temperature control output.
4	TX2	Output	Serial Port 2 Receiver, TTL Level, used for connecting to the Screen Display Control Module.
5	RX2	Input	Serial Port 2 Receiver, TTL Level, used for connecting to the Screen Display Control Module.
6	VCC	Output	3.3V Output, intended for connection to the screen display control module and not recommended for other uses.
7	TX1	Output	Serial Port 1 Receive End, TTL level, used for connecting to PC control software. Data bits: 8 bits, Stop bits: 1 bit, Parity: None, Baud Rate: 38400.
8	RX1	Input	Serial Port 1 Receive End, TTL level, used for connecting to PC control software. Data bits: 8 bits, Stop bits: 1 bit, Parity: None, Baud Rate: 38400.
9	NTC-	Input	Thermistor (NTC) Interface, compatible with different resistance values of NTC thermistors, with wiring polarity not required.
10	NTC+	Input	Thermistor (NTC) Interface, compatible with different resistance values of NTC thermistors, with wiring polarity not required.
11	GND	Input	Power Input Negative Pole (High Current).
12	GND	Input	Power Input Negative Pole (High Current).

13	Vin	Input	Power Input Positive Pole, with an input voltage range of 7 to 24V.
14	Vin	Input	Power Input Positive Pole, with an input voltage range of 7 to 24V.
15	TEC-	Output	The negative terminal of the temperature control current output is usually connected to the negative terminal of the Thermoelectric Cooler (TEC).
16	TEC-	Output	The negative terminal of the temperature control current output is usually connected to the negative terminal of the Thermoelectric Cooler (TEC).
17	TEC+	Output	The positive terminal of the temperature control current output is typically connected to the positive terminal of the Thermoelectric Cooler (TEC).
18	TEC+	Output	The positive terminal of the temperature control current output is typically connected to the positive terminal of the Thermoelectric Cooler (TEC).



Figure3 TEC103/TEC103L Adapter Board Wiring Diagram

05 Dimensional Drawing

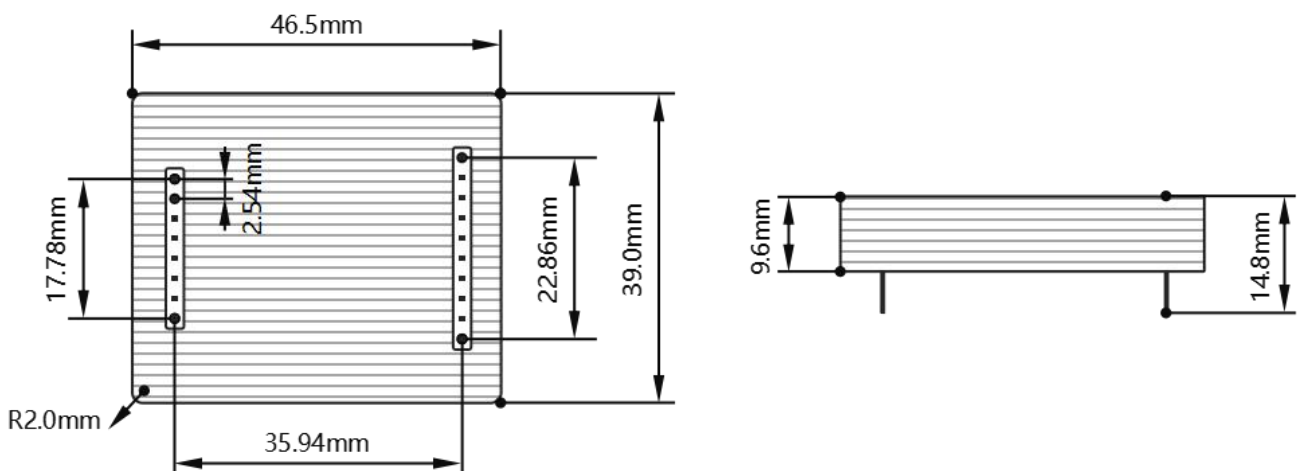

Figure4 Dimensional drawing of TEC103/TEC103L

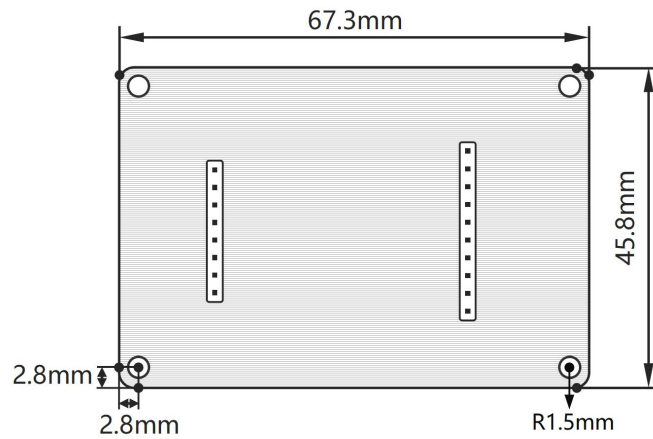

Figure5 Dimensional drawing of TEC103/TEC103L Evaluation Board

06 Computer Software (Communication Protocol Refer to Attachment)

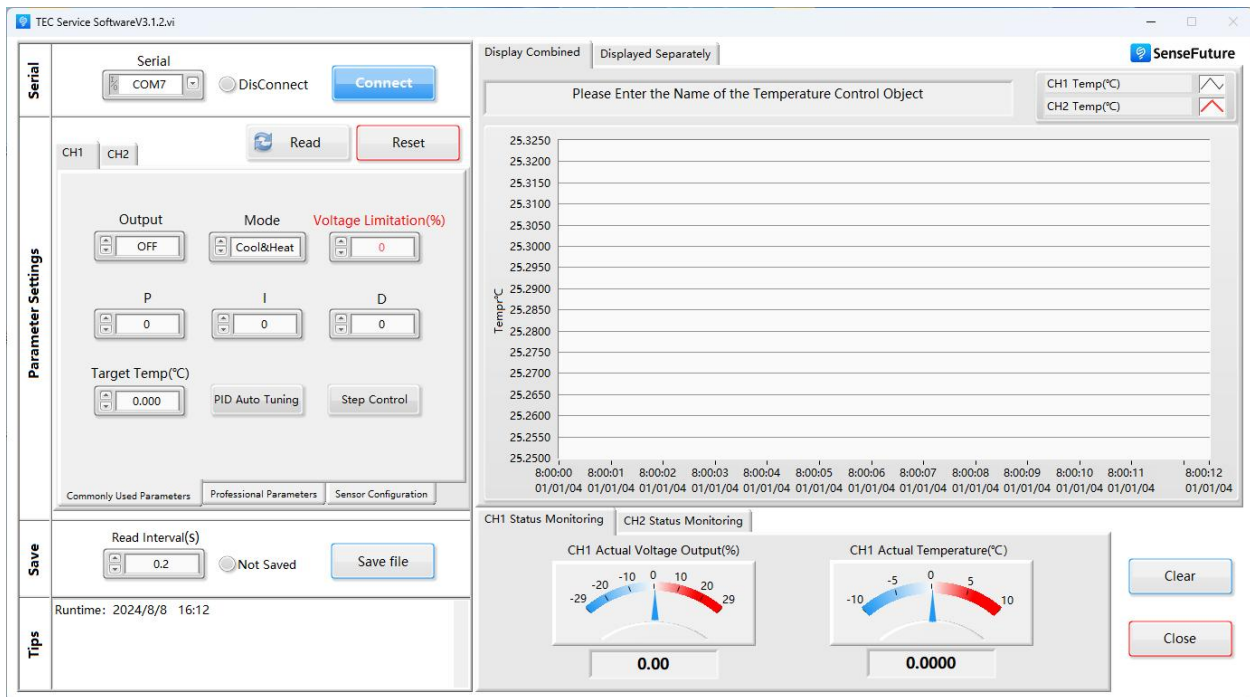

Figure6 Computer Software

Download:

<https://drive.google.com/file/d/1-2Ruffh7yyJPImV5w0OIUB0IyTqhbeRD/view?usp=sharing>

07 Instructional Video

YouTube



【SenseFuture】 ±0.001°C Temperature Controller (TEC103 Series) Instructions for Use

— DFB Laser Temperature Control

<https://www.youtube.com/watch?v=exZvXJUNZ1c>

08 Selection Guide

Table3 Temperature Controllers Selection Guide

MODEL	STABILITY (°C)@20°C	SENSOR TYPES	CHANNELS	DRIVING CAPACITY @24V	POWER SUPPLY VOLTAGE(V)	FEATURES
TEC103L	±0.01	NTC	1	±3A	7-24	Single-channel, Compact
TEC103	±0.001					
TEC207L	±0.01	NTC PT1000	2	±7A each channel		Dual-channel, Medium Current
TEC207	±0.001					
TEC215L	±0.01			Dual-channel, High-current, Solid State Relay		
TEC215	±0.001					
TEC215 pro	±0.001	NTC PT1000 CCR Low Temperature Resistor	±80A/Solid State Relay	Dual-channel, High-current, Solid State Relay, Polynomial Temperature Calibration		

Temperature Measurement Range and Sensitivity of Temperature Sensors Compatible with
TEC103/207/215

Sensitivity	NTC (500k B4250)	NTC (100k B3950)	NTC (10k B3950)	NTC (1k B3470)	PT1000	PT100
≤±0.001°C	60~300°C	25~210°C	-20~150°C	-60~70°C	-200~800°C	—
≤±0.01°C	300~470°C	210~350°C	150~200°C	70~110°C	—	-200~800°C
≤±0.1°C	470~550°C	350~500°C	200~290°C	110~180°C	—	—

Temperature Measurement Range and Sensitivity of Temperature Sensors Compatible with
TEC103L/207L/215L

Sensitivity	NTC (500k B4250)	NTC (100k B3950)	NTC (10k B3950)	NTC (1k B3470)	PT1000	PT100
≤±0.01°C	60~400°C	25~290°C	-20~180°C	-60~100°C	-200~800°C	—
≤±0.1°C	400~550°C	290~430°C	180~280°C	100~130°C	—	-200~800°C
≤±1°C	—	430~550°C	—	130~180°C	—	—

09 Customized Temperature Control System Services

We offer complete temperature control solutions, providing custom temperature control systems for institutions such as the National Institute of Metrology of China, the Anhui Institute of Optics and Fine Mechanics, Nanjing University, and Shenzhen University.

For customized temperature control systems, please contact our technical support at +86 191 2054 5883 (WhatsApp ID same as phone number)

Attachment 1. Typical Application Cases

01 DFB Semiconductor Laser Temperature Control Case Study

- **Temperature Control Object Information:** A domestically manufactured Distributed Feedback (DFB) laser diode operating at a wavelength of 1370nm and a power output of 10mW.
- **Temperature Sensor Specification:** The laser module incorporates an NTC 10K B3950 thermistor internally.
- **Heating/Cooling Device:** The laser features an integrated thermoelectric cooler (TEC) capable of 1.5A at 2.6V.
- **Temperature Controller Brand and Model:** *SenseFuture*TM TEC103.
- **Target Temperature:** 25°C.
- **Temperature Controller Settings:** Power supply voltage is 12V, with a maximum output voltage percentage set at 20% (i.e., $12V \times 20\% = 2.4V$); PID parameters configured as P = 200, I = 100, D = 0, with a positive hysteresis duty cycle of 0.005%, and a negative hysteresis duty cycle also at 0.005%.
- **Measured Results:** The actual temperature stability achieved is $\pm 0.0005^\circ\text{C}$ after 5 hours of testing under ambient conditions of $25 \pm 1.5^\circ\text{C}$, and $\pm 0.0005^\circ\text{C}$ maintained over a 24-hour period, again within an ambient range of $25 \pm 1.5^\circ\text{C}$.

(Need a specific solution? Please consult technical support for quotation at +86 191 2054 5883)

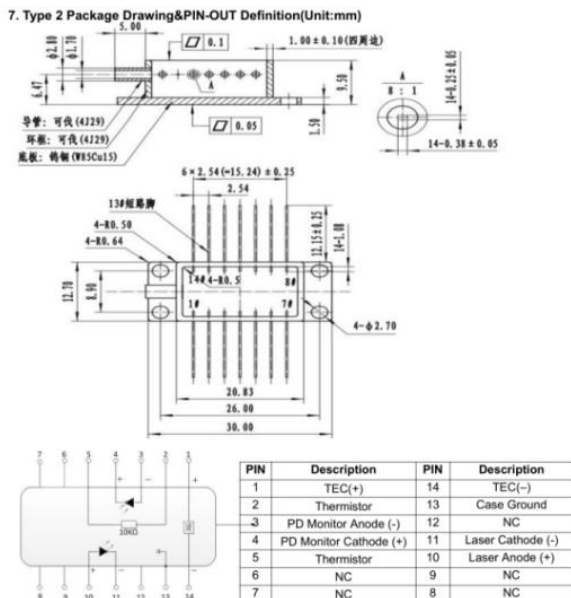

3. Absolute Maximum Ratings:

Parameter	Symbol	Condition	Min.	Max.	Unit
Laser forward DC current	-	-	-	120	mA
LD Reverse voltage	V_{RLD}	CW	-	2.0	V
TEC voltage	V_{TEC}	CW	-	2.6	V
TEC Current	I_{TEC}	CW	-	1.5	A
Lead solder temperature/Time	-	-	-	260/10	$^\circ\text{C}/\text{S}$
Operating temperature	T_{OP}	Case temperature	-40	+85	$^\circ\text{C}$
Storage temperature	T_{STG}	Ambient temperature	-40	+85	$^\circ\text{C}$

4. Optical-Electro Characteristics($T=25^\circ\text{C}$, $I_F=I_{OP}$):

Parameter	Symbol	Condition	Min.	Typ.	Max.	Unit
Operating wavelength	λ_c	CW, 25 $^\circ\text{C}$	λ_{c-3}	λ_c	λ_{c+3}	nm
Optical output power	P_F	-	6	10	-	mW
Threshold current	I_{TH}	25 $^\circ\text{C}$	-	8	15	mA
Operating current	I_{OP}	CW	-	-	90	mA
Operating voltage	V_{OP}	25 $^\circ\text{C}$	-	1.1	2.0	V
Side mode suppression ratio	SMSR	-	35	40	-	dB
Optical isolation	I_{SO}	25 $^\circ\text{C}$	35	-	-	dB
Spectral width (-20 dB)	$\Delta\lambda$	-	-	0.1	1.0	nm
Polarization extinction ratio	ER	PM fiber	18	-	-	dB
Wavelength temp. coefficient	$\Delta\lambda/\Delta T$	-	-	0.08	0.12	nm/ $^\circ\text{C}$

Figure Attached1.1 Dimensions and Basic Parameter Information for the DFB Laser

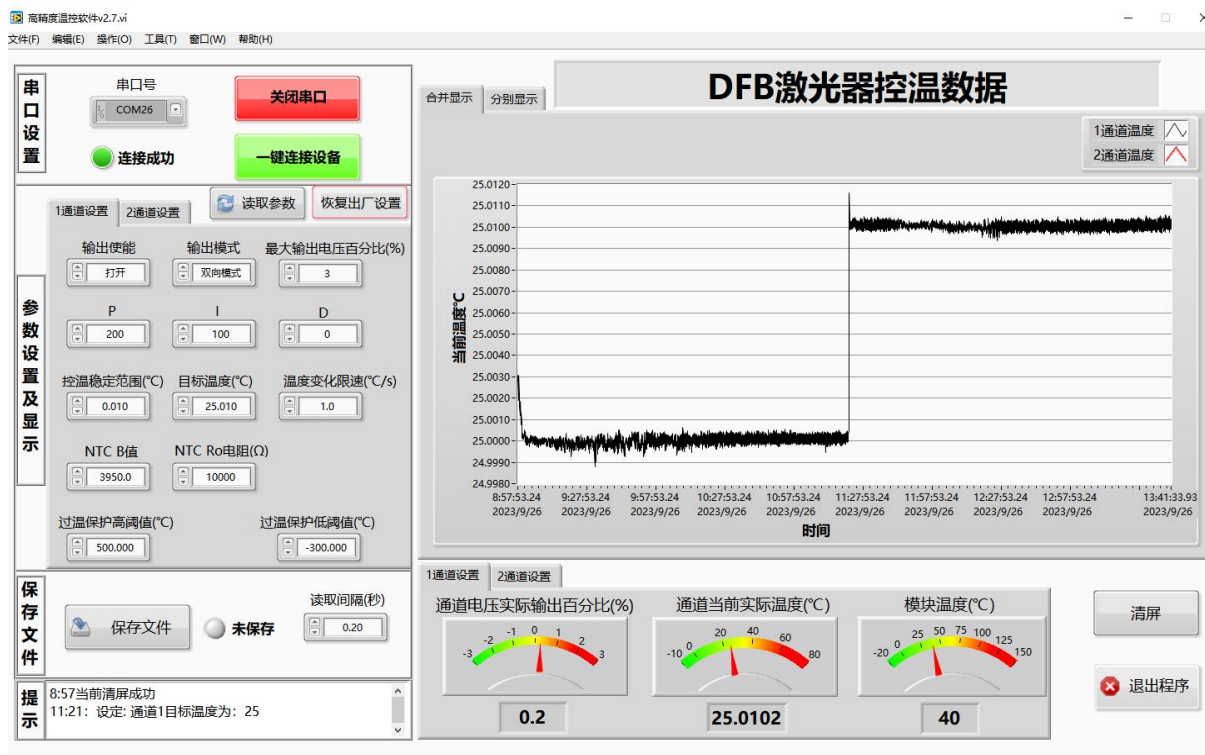

Figure Attached1.2 Actual Temperature Control Test Data for the DFB Laser

02 ICL Semiconductor Laser Temperature Control Case Study

Performance is similar to 01, with specific details to be shared upon update.

(Need a specific solution? Please consult technical support for quotation at +86 191 2054 5883)

03 LD Laser Diode Temperature Control Case Study

Performance is similar to 01, with specific details to be shared upon update.

(Need a specific solution? Please consult technical support for quotation at +86 191 2054 5883)

04 QCL Temperature Control Case Study

- **Temperature Control Object Details:** QCL (Quantum Cascade Laser) with a wavelength of 4332nm and a power output of 100mW.
- **Temperature Sensor:** An internal NTC 10K B3950 thermistor built into the laser.
- **Heating/Cooling Device:** An integrated thermoelectric cooler (TEC) within the laser operating at 7V.
- **Temperature Controller Brand and Model:** **SenseFuture™ TEC103.**
- **Target Temperature:** 47°C.
- **Temperature Controller Settings:** Supply voltage is 12V, with a maximum output voltage setting of 20% (corresponding to 12V x 20% = 2.4V), PID parameters configured as

P = 5000, I = 500, and D = 0.

- **Actual Test Results:** Achieved temperature stability was $\pm 0.001^{\circ}\text{C}$ over a 1-hour test period.

(Need a specific solution? Please consult technical support for quotation at +86 191 2054 5883)

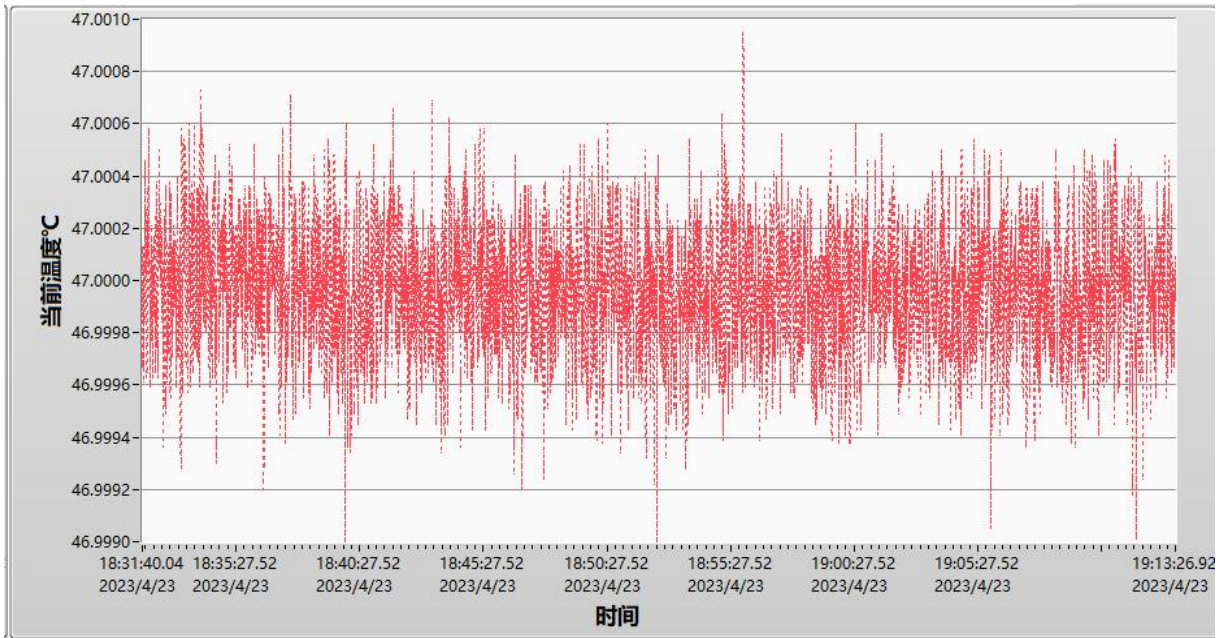

Figure Attached1.3 Long-term Temperature Control Data for QCL Laser

05 MCT Detector Temperature Control Case Study

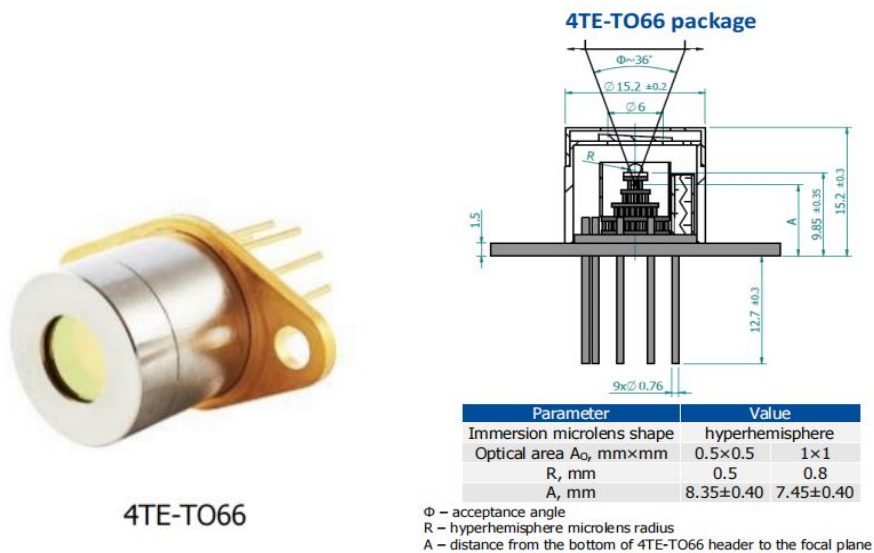

Figure Attached1.4 MCT Detector

- **Temperature Control Object Information:** MCT Detector from brand *VIGO*.
- **Temperature Sensor:** Built-in NTC 2K B3950 thermistor inside the detector.
- **Heating/Cooling Element:** Integrated thermoelectric cooler (TEC) within the detector rated at 1V and 100mA.
- **Temperature Controller Brand and Model:** *SenseFuture*™ TEC103.

- **Target Temperature:** 25°C.
- **Temperature Controller Settings:** Power supply voltage is 9V with a maximum output voltage percentage of 3% (which translates to $9V \times 3\% = 0.27V$), PID parameters set to P = 15, I = 5, and D = 0.
- **Measured Results:** Achieved temperature stability of $\pm 0.0025^\circ\text{C}$ over a 14-hour test period.

(Need a specific solution? Please consult technical support for quotation at +86 191 2054 5883)

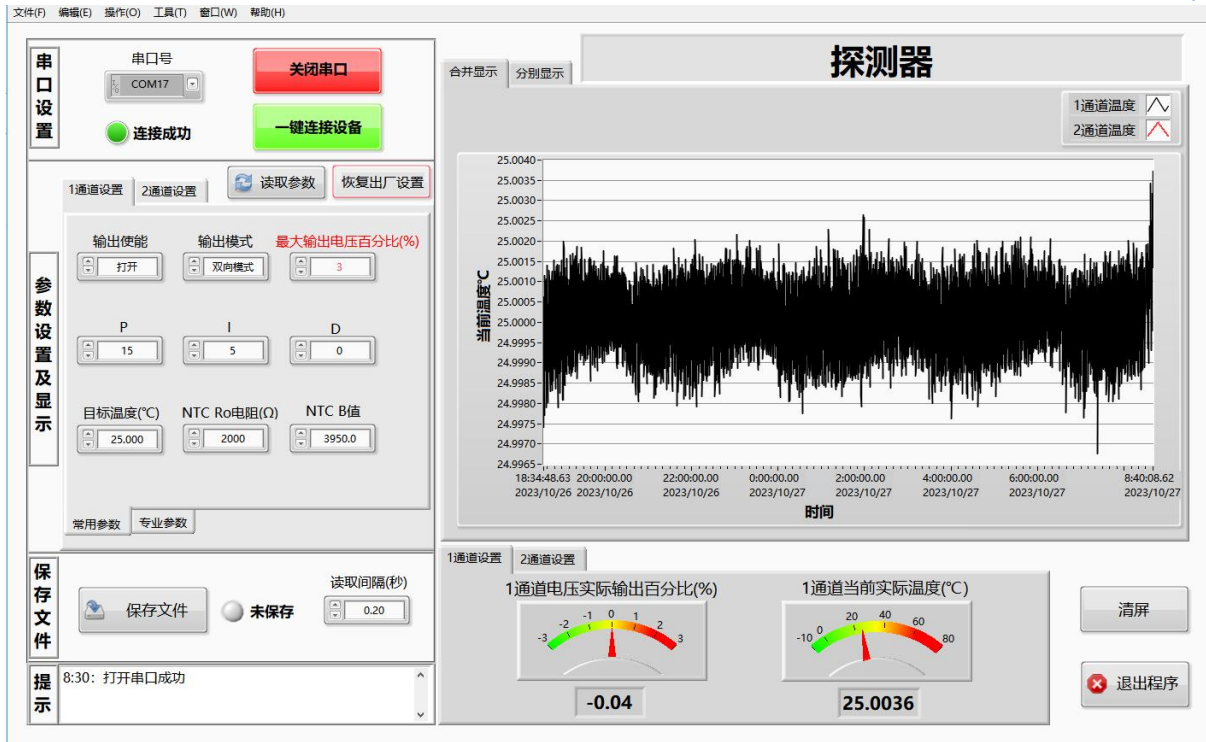

Figure Attached1.5 Temperature Control Data for MCT Detector

Partners

01 Universities and Research Institutes



02 Optical Instrument Technology Company



Add: 4F/16F, Building B, Gaoke Innovation Center, Guangming
District, Shenzhen, Guangdong, China

Tel: +86 191 2054 5883

Mail: sales@sensefuture.com

Web: www.sensefuture.com / www.sensefuture.com.cn



**Original Aspiration Determines the Future,
Innovation Creates Value,
Sharing Unites Hearts.**

**Looking forward to achieving win-win
cooperation with you!**

Download

