

Creality Nebula Smart Kit Instruction Manual

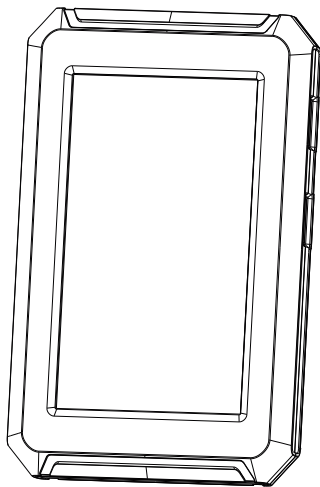

FCC Caution:

Any Changes or modifications not expressly approved by the party responsible for compliance could void the user's authority to operate the equipment. This device complies with part 15 of the FCC Rules.

Operation is subject to the following two conditions:

- (1) This device may not cause harmful interference, and
- (2) this device must accept any interference received, including interference that may cause undesired operation.

IMPORTANT NOTE:

Note: This equipment has been tested and found to comply with the limits for a Class B digital device, pursuant to part 15 of the FCC Rules. These limits are designed to provide reasonable protection against harmful interference in a residential installation. This equipment generates, uses and can radiate radio frequency energy and, if not installed and used in accordance with the instructions, may cause harmful interference to radio communications. However, there is no guarantee that interference will not occur in a particular installation. If this equipment does cause harmful interference to radio or television reception, which can be determined by turning the equipment off and on, the user is encouraged to try to correct the interference by one or more of the following measures: -Reorient or relocate the receiving antenna.

- Increase the separation between the equipment and receiver.
- Connect the equipment into an outlet on a circuit different from that to which the receiver is connected.
- Consult the dealer or an experienced radio/TV technician for help.

FCC Radiation Exposure Statement:

This equipment complies with FCC radiation exposure limits set forth for an uncontrolled environment. This equipment should be installed and operated with minimum distance 20cm between the radiator & your body

Precautions for use

1. Please use the product strictly in accordance with this manual to avoid personal injury and property damage.
2. Do not place the machine near any heat source or flammable or explosive objects. We suggest placing it in a well-ventilated, low-dust environment.
3. Please use the power adapter that comes with the machine to prevent damage to the machine.
4. Do not place this product in a vibration or unstable environment.
5. Please power off to clean the product regularly.
6. Users should comply with the laws and regulations of the corresponding countries and regions where the equipment is located (used), abide by professional ethics, pay attention to safety obligations, and strictly prohibit the use of our products or equipment for any illegal purposes. Creality will not be responsible for any violators' legal liability under any circumstance.

Firmware upgrade

1. OTA Online Upgrade: Connect to Wi-Fi to receive the latest firmware updates online;
2. USB Offline Upgrade: Visit the official website to download the latest firmware and perform the upgrade via a USB flash disk.

Download Path: [<https://www.creality.com/pages/download> → Ecosystem → Creality Nebula Smart Kit

1. Product description

Product name:	Creativity Nebula PadN
Product model:	N-Pad 01
Main control chip:	dual-core 1.2GHz
Storage memory:	8G
Screen type:	IPS
Screen size:	4.3inch
Screen resolution:	272*480
TouchI mode:	resistive touch
WiFi protocol:	802.11b/g/n
USB interface:	USB2.0
Rated voltage:	5V
Vibration sensor:	Yes
Resume printing:	support
Filament run-out detection:	support
Supported languages:	10 languages
Product size:	133.17*83.3*19.6mm
Net weight:	145g

*10 languages

(Chinese, English, Japanese, German, French, Italian, Spanish, Portuguese, Russian, Turkish)

Model:	NC01
Highest Resolution:	1920*1080
Field of View:	H: 95° D: 112°
Night Vision:	Supports automatic switching
Manual Focus:	Supports MF, knob adjustment
Connection:	USB connection
Rated Voltage:	5V
Product Dimensions:	55*40*35mm
Net Weight:	130g

2. Packing list

1. Nebula Pad	x1
2. Nebula Camera	x1
3. U disk	x1
4. Tripod	x1
5. G-Sensor cable	x1
6. G-Sensor	x1

7. Cross pan head self-tapping screw M3*8 x2

8. Hexagon socket head screw M3*6 x2

9. Hexagon socket head screw M3*8 x2

10. Hexagon socket head screw M5*10 x3

11. M5 T-nut x3

12. Cable tie x5

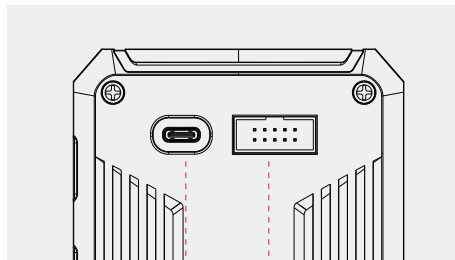

G-sensor interface

Printer cable interface

3.Product view and interface description

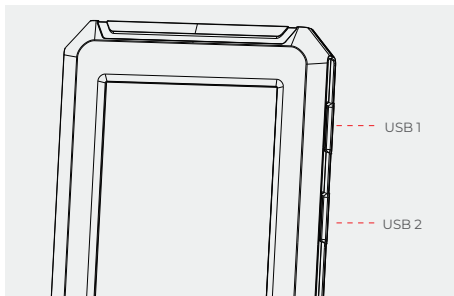

USB 1

USB 2

G-Sensor cable

Nebula Pad Independent Power Connector (5V):

When the Nebula pad lacks power supply while connected to peripherals like cameras, it requires a separate power supply.

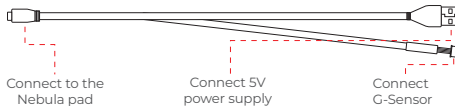

Connect to the
Nebula pad

Connect 5V
power supply

Connect
G-Sensor

4. Installation steps (take Ender-3V2 Neo as an example)

Model download path:

<https://www.creality.com/pages/download> → Ecosystem
→ Creality Nebula Smart Kit

4.1 Nebula pad installation

1. Obtain and print the bracket STL model in the U disk or the official website download center;
2. Place the screen bracket on the side of the profile on the right, and tighten it with 3 M5X10 screws and T-nuts;
3. Align the Nebula pad with the bracket and slide down to lock it tightly
4. Connect the display cable.

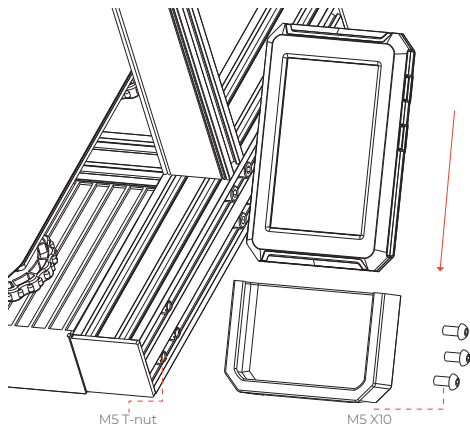

4.2 G-Sensor and Nebula Camera Installation

M3*8 self-tapping screw

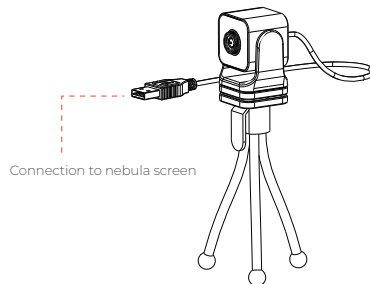
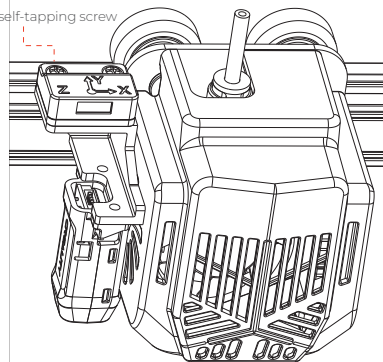

Note: Time-lapse photography files can be viewed on the Creality Cloud

5. Boot guide and device interface introduction

5.1 Boot guide

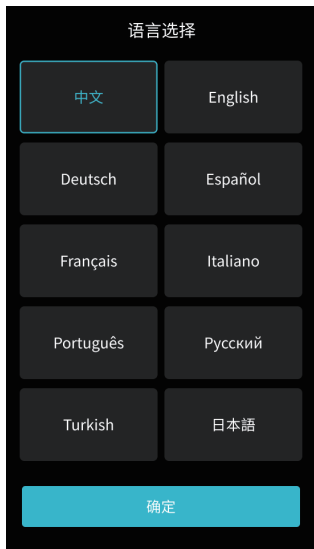

1

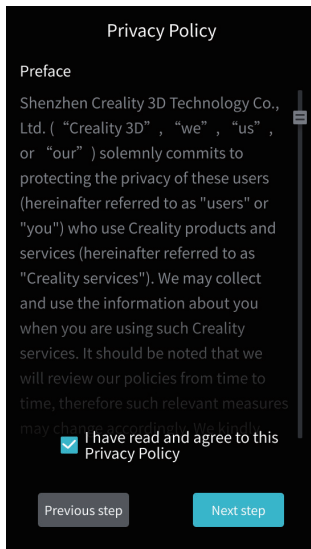

2



3

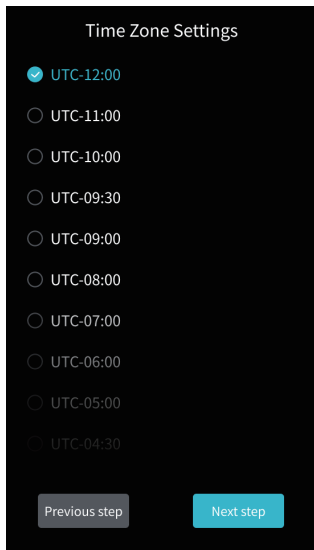

4

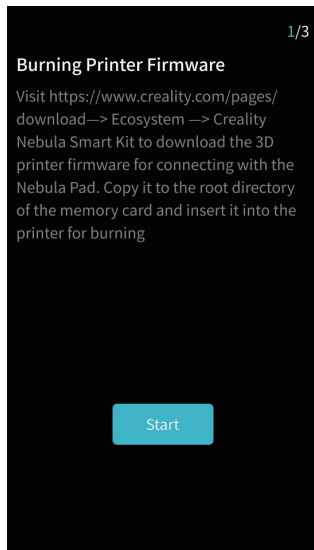

5

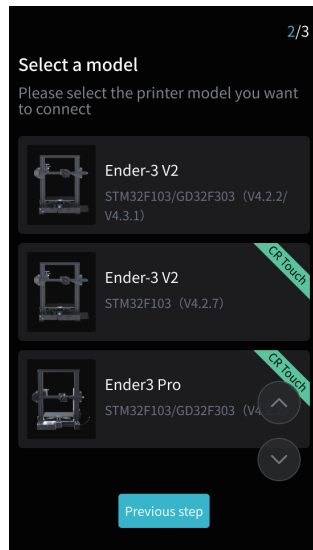

6

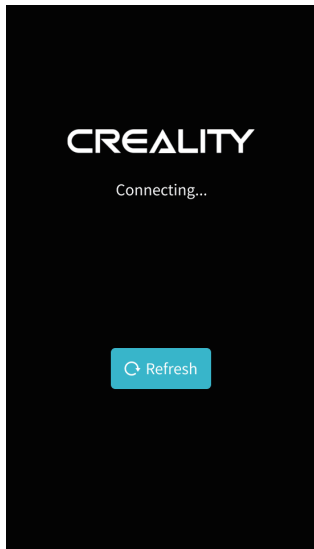

7

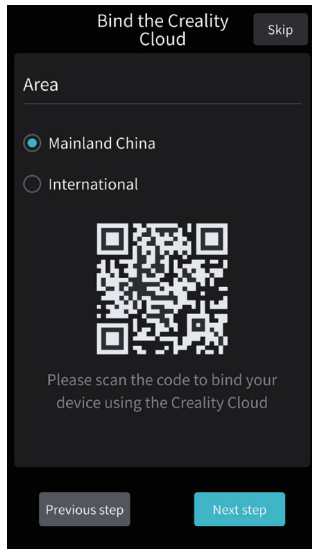

8

Notice:

The current UI is for reference only. As the firmware is constantly being upgraded, please refer to the latest firmware UI on the official website.

5.2 Printer self-test

Printer self-check



Welcome to the self-test process

1. Please place the printing platform
2. The self-test process is expected to take around 11 minutes

Previous step **Start detecting**

1

1/7 Heat break fan detection



Heat break fan position

Please check if the heat break cooling fan is rotating properly

1. Proceed to the next step if rotating normally;
2. If not, please check the manual or contact customer service.

Start detecting

Previous step **Next step**

2

2/7 Model fan detection



Model fan position

Please check if the model cooling fan is rotating properly

1. Proceed to the next step if rotating normally;
2. If not, please check the manual or contact customer service.

Start detecting

Previous step **Next step**

3

3/7 Axis movement detection

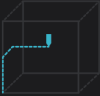

Homing test

1. Please place the printing platform
2. Axis movement detection is expected to take about 1 minute

Start detecting

Previous step Next step

4

4/7 Z-axis offset



Platform calibration

1. Adjust the spacing between nozzle and platform to the right position

0.01mm 0.05mm

-0.28

Previous step Next step

5

5/7 Manual leveling Skip

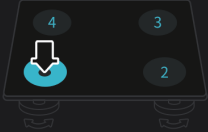

Please operate at the position shown in the picture

1. Please ensure that the hotbed and nozzle surfaces are clean
2. Please click on the numbers in the picture for extruder positioning
3. Wait for the extruder to move to the appropriate position
4. Adjust the leveling button

Previous step Next step

6

6/7 Auto Leveling Skip

21	22	23	24	25
20	19	18	17	16
11	12	13	14	15
10	9	8	7	6
1	2	3	4	5



Please start auto leveling
 1. Please place the printing platform
 2. Leveling process is expected to take about 5 minutes

25/60 °C Start leveling

Previous step Next step

7

7/7 Optimization of vibration veins Skip

Type 1 Type 2

Please confirm the current machine type
 1. Type 1 hotbed on the Y-axis
 2. Type 2 hotbed not on the Y-axis

OK

Previous step Next step

8

Detection results

- Heat break fan detection ✓
- Model fan detection ✓
- Axis movement detection ✓
- Z-axis offset ✓
- Manual leveling ✓
- Auto Leveling ✓
- Optimization of vibration veins ✓

Previous step Next step

9

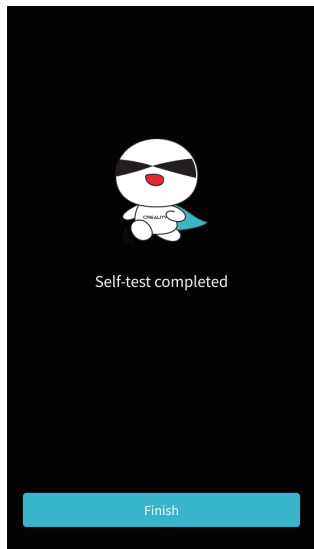

10

Warm reminder:

If there is an abnormality during the self-inspection, you can first refer to the FAQ to find the cause of the fault; or scan the QR code to report the fault, and then solve the fault through after-sales service

Notice:

The current UI is for reference only. As the firmware is constantly being upgraded, please refer to the latest firmware UI on the official website.

5.3 Device interface introduction

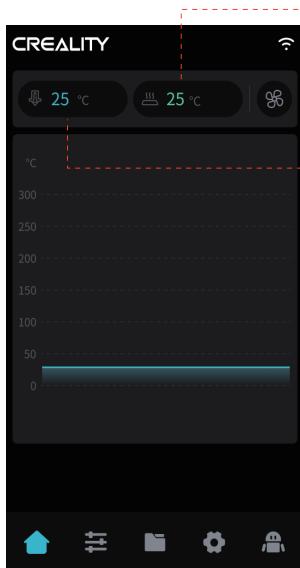

Home page

Heated bed temperature

Nozzle temperature

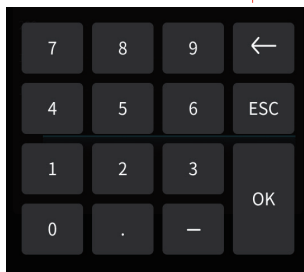

Parameters can be set manually

Notice:

The current UI is for reference only. As the firmware is constantly being upgraded, please refer to the latest firmware UI on the official website.

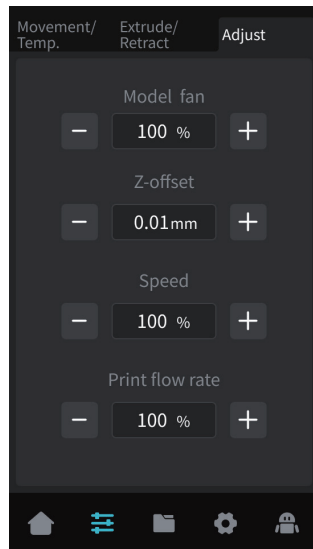
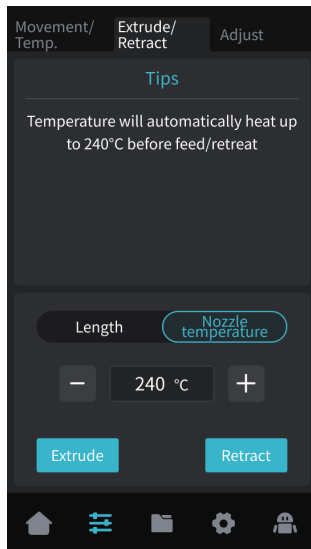
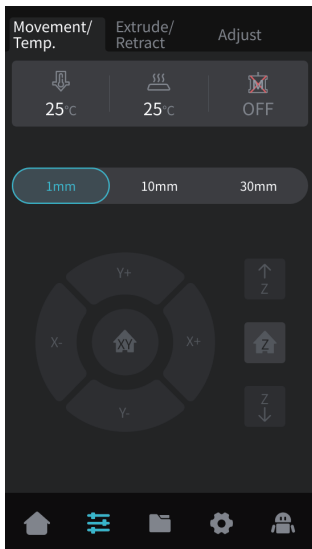

Preparation

Function settings such as axis movement/temperature/feed and retreat, model fan cooling, etc. can be set through the preparation interface.

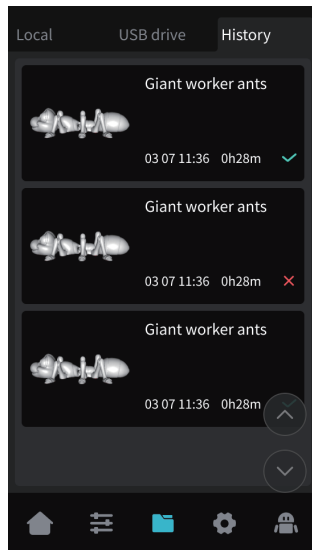
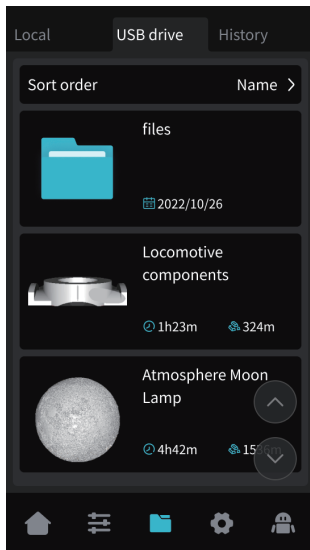
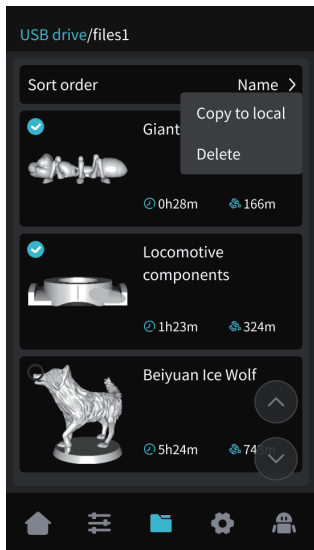

Long press the model to select multiple and copy to the USB drive.

*Can copy up to 3 models

Print file preview

Local and USB drive model files can be managed on the print file preview interface

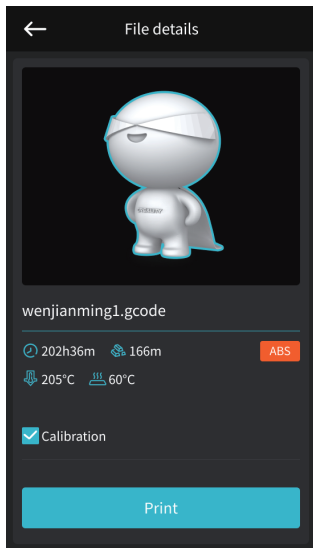

Click on the model file to view the file details
*Tick Print Calibration to improve print quality.

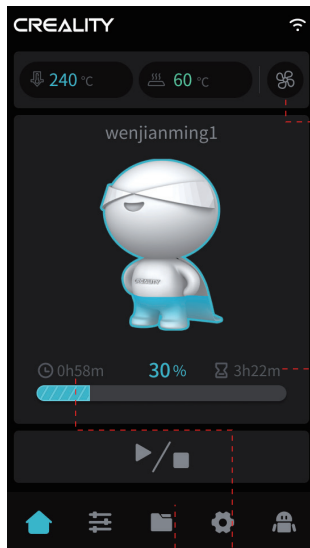

Print page

Print time

Model fan on/off

Notice:

The current UI is for reference only. As the firmware is constantly being upgraded, please refer to the latest firmware UI on the official website.

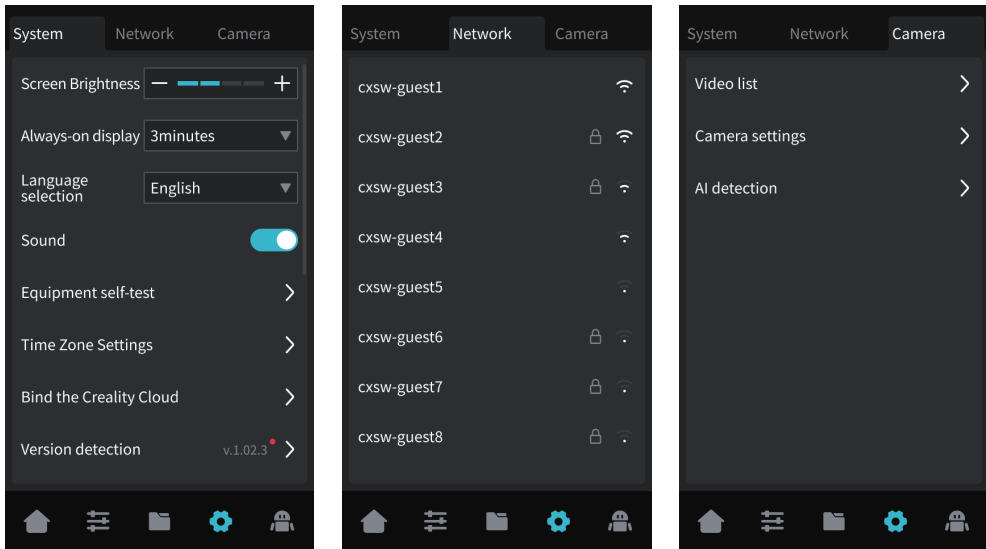

Setting

Function settings such as Nebula pad system, network, and camera can be set through the Setting.

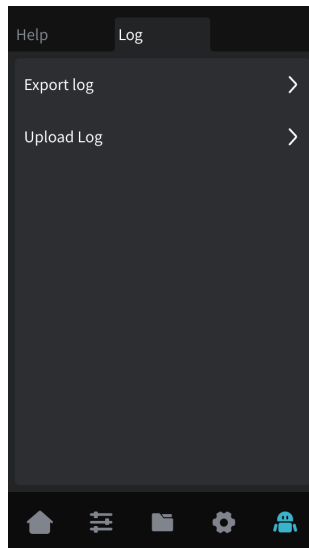
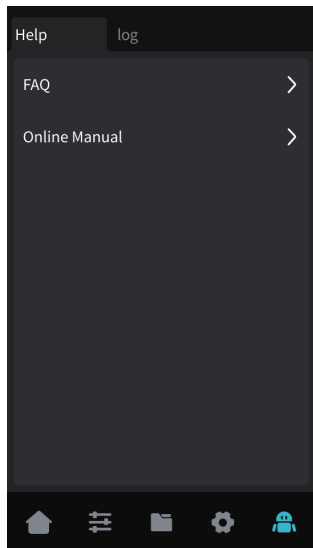

Customer Service Interface

You can view FAQs, manuals, and log management through the customer service page.

Notice:

The current UI is for reference only. As the firmware is constantly being upgraded, please refer to the latest firmware UI on the official website.

6. Remote control

6.1 Device interface in CreaLity Print slicing software

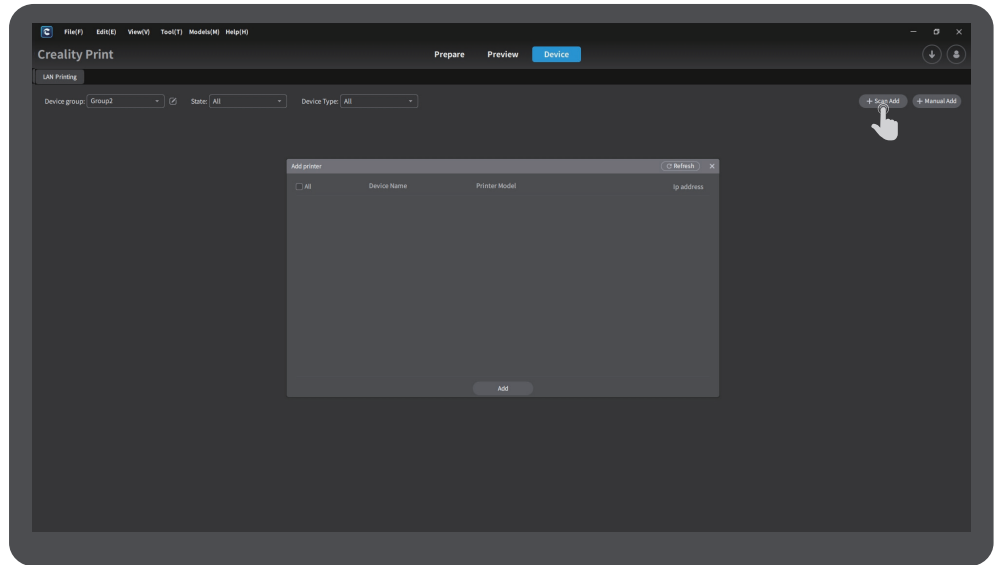

Add device: a. Scan to add → select device

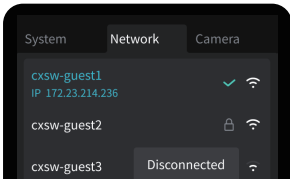

Click "Settings" → "Network", select the connected network to view the IP address

Add device: b. Manually enter the IP address to add the device

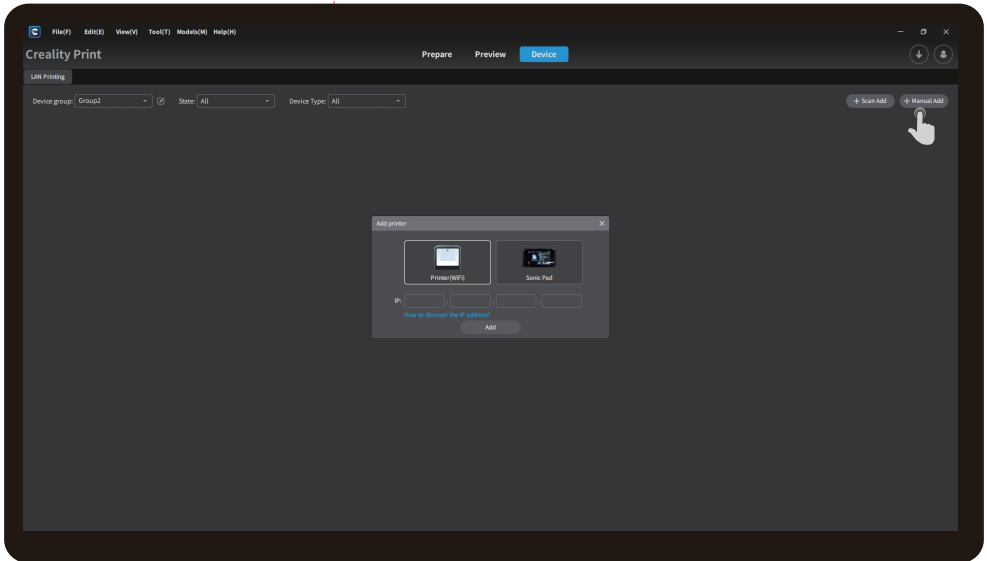

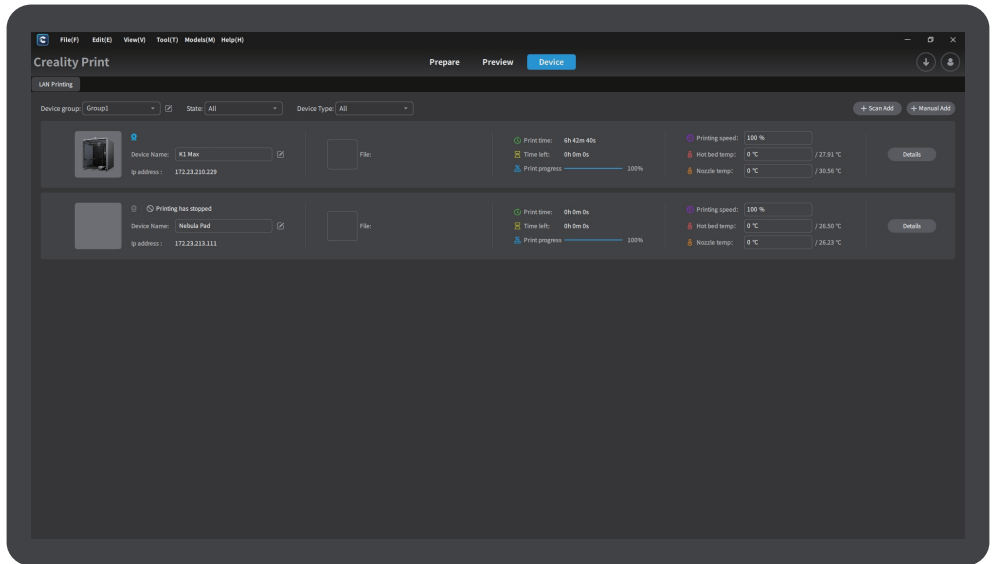

Device list

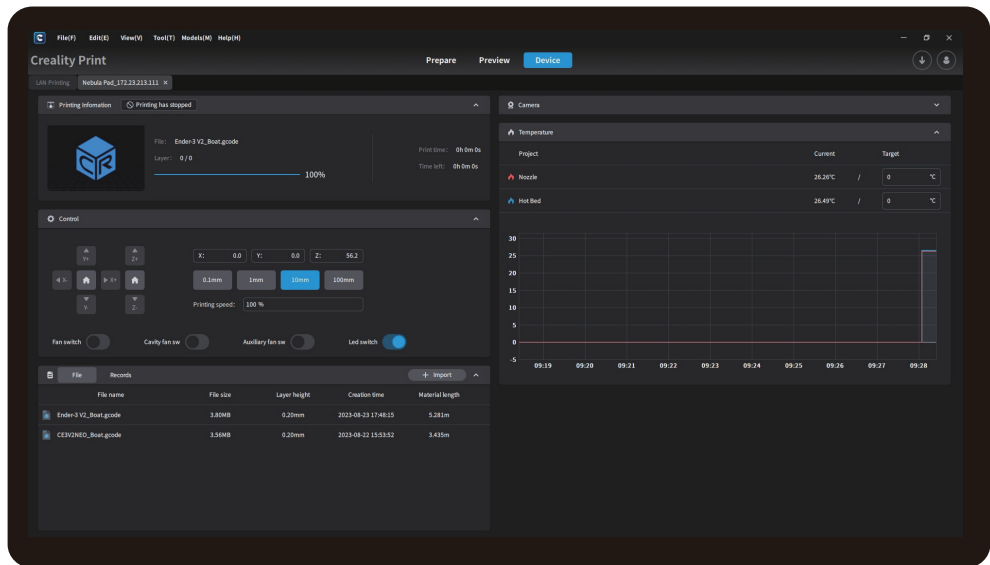

Device print information details

Notice

The current UI is for reference only. As the firmware is constantly being upgraded, please refer to the latest firmware UI on the official website.

6.2 Crealty cloud APP control

After binding the Crealty cloud account on the Crealty Nebula Pad, you can remotely control it through the app

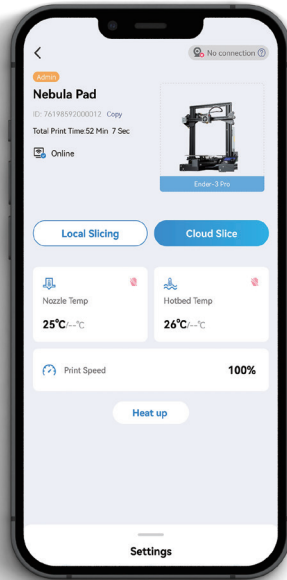

MADE IN CHINA



Join the Facebook Community
<https://www.facebook.com/groups/sonicpad>
+86 755 3396 5666
cs@creality.com

SHENZHEN CREALITY 3D TECHNOLOGY CO.,LTD.

Official Website: www.creality.com

Business Tel: +86 755-8523 4565 E-mail: cs@creality.com

Company Address: 18th Floor, JinXiuHongDu Building, Meilong Road, Xinniu Community, Minzhi Street, Longhua District, Shenzhen City, China.

